

DRAPER[®] STORMFORCE[®]

INSTRUCTIONS FOR 20V Cordless Impact Wrench

Stock No.82983 Part No.CIW20LISF
Stock No.01031 Part No.CIW20GSF

IMPORTANT: PLEASE READ THESE INSTRUCTIONS CAREFULLY TO ENSURE THE SAFE AND EFFECTIVE USE OF THIS PRODUCT.



DRAPER[®]

GENERAL INFORMATION

These instructions accompanying the product are the original instructions. This document is part of the product, keep it for the life of the product passing it on to any subsequent holder of the product. Read all these instructions before assembling, operating or maintaining this product.

This manual has been compiled by Draper Tools describing the purpose for which the product has been designed, and contains all the necessary information to ensure its correct and safe use. By following all the general safety instructions contained in this manual, it will ensure both product and operator safety, together with longer life of the product itself.

All photographs and drawings in this manual are supplied by Draper Tools to help illustrate the operation of the product. Whilst every effort has been made to ensure the accuracy of information contained in this manual, the Draper Tools policy of continuous improvement determines the right to make modifications without prior warning.

1. TITLE PAGE

1.1 INTRODUCTION:

USER MANUAL FOR:

20V CORDLESS IMPACT WRENCH

Stock No's. 82983, 01031

Part No's. CIW20LISF, CIW20GSF

1.2 REVISIONS:

Date first published September 2017

As our user manuals are continually updated, users should make sure that they use the very latest version.

Downloads are available from: <http://www.drapertools.com/manuals>

DRAPER TOOLS LIMITED
HURSLEY ROAD
CHANDLER'S FORD
EASTLEIGH
HAMPSHIRE
SO53 1YF
UK

WEBSITE: drapertools.com
PRODUCT HELP LINE: +44 (0) 23 8049 4344
GENERAL FAX: +44 (0) 23 8026 0784

1.3 UNDERSTANDING THIS MANUALS SAFETY CONTENT:

WARNING! Information that draws attention to the risk of injury or death.

CAUTION! Information that draws attention to the risk of damage to the product or surroundings.

1.4 COPYRIGHT © NOTICE:

Copyright © Draper Tools Limited.

Permission is granted to reproduce this publication for personal & educational use only.

Commercial copying, redistribution, hiring or lending is prohibited.

No part of this publication may be stored in a retrieval system or transmitted in any other form or means without written permission from Draper Tools Limited.

In all cases this copyright notice must remain intact.

2. CONTENTS

2.1 CONTENTS

CONTENT	PAGE
1 TITLE PAGE	
1.1 INTRODUCTION	2
1.2 REVISION HISTORY	2
1.3 UNDERSTANDING THIS MANUAL	2
1.4 COPYRIGHT NOTICE	2
2 CONTENTS	
2.1 CONTENTS	3
3 GUARANTEE	
3.1 GUARANTEE	4
4 INTRODUCTION	
4.1 SCOPE	5
4.2 SPECIFICATION	5
4.3 HANDLING & STORAGE	5
5 HEALTH & SAFETY INFORMATION	
5.1 GENERAL SAFETY INSTRUCTIONS FOR POWER TOOL USE	6
5.2 ADDITIONAL SAFETY INSTRUCTIONS FOR IMPACT WRENCHES	7
5.3 RESIDUAL RISK	8
5.4 SAFETY INSTRUCTIONS FOR BATTERY PACKS/CHARGERS	8
5.5 CONNECTION TO THE POWER SUPPLY	9
6 TECHNICAL DESCRIPTION	
6.1 IDENTIFICATION	10
7 UNPACKING & CHECKING	
7.1 PACKAGING	11
7.2 WHAT'S IN THE BOX?	11
8 PREPARING THE IMPACT WRENCH	
8.1 BATTERY CHARGING	12
8.2 BATTERY PACK CHARGE STATUS	13
8.3 BATTERY LIFE EFFICIENCY AND CHARGING ADVICE	13
9 BASIC OPERATION	
9.1 INSTALLING AND REMOVING SOCKETS	14
9.2 ROTATIONAL DRIVE SELECTION	14
9.3 VARIABLE SPEED TRIGGER	15
9.4 BELT CLIP	15
9.5 OPERATION	15
10 MAINTENANCE AND TROUBLESHOOTING	
10.1 MAINTENANCE	16
10.2 TROUBLESHOOTING	16
10.3 REPLACEMENT ACCESSORIES	16
11 DISPOSAL	
11.1 DISPOSAL	17
11.2 HEALTH AND SAFETY FOR BATTERIES	17
11.3 DISPOSAL	17
12 EXPLANTATION OF SYMBOLS	
12.1 EXPLANATION OF SYMBOLS	18
DECLARATION OF CONFORMITY	ENCLOSED

3. GUARANTEE

3.1 GUARANTEE

Draper tools have been carefully tested and inspected before shipment and are guaranteed to be free from defective materials and workmanship.

Should the tool develop a fault, please return the complete tool to your nearest distributor or contact Draper Tools Limited, Chandler's Ford, Eastleigh, Hampshire, SO53 1YF. England.

Telephone Sales Desk: (023) 8049 4333 or Product Help Line (023) 8049 4344.

A proof of purchase must be provided with the tool.

If upon inspection it is found that the fault occurring is due to defective materials or workmanship, repairs will be carried out free of charge. This guarantee period covering parts/labour is 12 months from the date of purchase except where tools are hired out when the guarantee period is 90 days from the date of purchase. The guarantee is extended to 24 months for parts only. This guarantee does not apply to normal wear and tear, nor does it cover any damage caused by misuse, careless or unsafe handling, alterations, accidents, or repairs attempted or made by any personnel other than the authorised Draper warranty repair agent.

Note: If the tool is found not to be within the terms of warranty, repairs and carriage charges will be quoted and made accordingly.

This guarantee applies in lieu of any other guarantee expressed or implied and variations of its terms are not authorised.

Your Draper guarantee is not effective unless you can produce upon request a dated receipt or invoice to verify your proof of purchase within the guarantee period.

Please note that this guarantee is an additional benefit and does not affect your statutory rights. Draper Tools Limited.

4. INTRODUCTION

4.1 SCOPE

This hand held, lithium-ion battery powered impact wrench is intended to tighten and loosen mechanical fixings (nuts, bolts, etc).

There is no mechanism for adjusting or regulating the output torque. All fixings should be finished using a torque wrench.

Warning! This wrench is very powerful and is capable of shearing off bolt heads. Take due care in this respect.

4.2 SPECIFICATION

Stock No's.	82983, 01031
Part no.	CIW20LISF, CIW20GSF
Battery:	
Type	Li-ion
Rated voltage.....	20V
Rating	3.0Ah
Charger:	
Rated voltage.....	230V
Rated frequency	50Hz
Rated D.C. output voltage	21V
Rated D.C. output current.....	2.4A
Protective device rated current	3.15A
Construction	Class II
Revolutions per min. (no load).....	0 – 2200r/min
Square drive	½"
Max. torque (±10%).....	400Nm
.....	295lbs-ft
Break away torque (±10%).....	1200Nm
.....	900lbs-ft
Max. reverse torque (±10%).....	400Nm
.....	295lbs-ft
Impact rate	2900ipm
Sound pressure level	84dB(A), K=3 db(A)
Sound power level	95dB(A), K=3 db(A)
Vibration level:.....	9.09m/s ² K=1.5 m/s ²
Weight (wrench and battery only).....	2.56kg

4.3 HANDLING & STORAGE

Care and attention must be observed during and after use to make sure the service life is maintained.

Do not drop this impact wrench or expose it to damp or hot environments.

Store it out of the reach of children.

5. HEALTH & SAFETY INFORMATION

5.1 GENERAL SAFETY INSTRUCTIONS FOR POWER TOOL USE

When using any type of power tool there are steps that should be taken to make sure that you, as the user, remain safe.

Common sense and a respect for the tool will help reduce the risk of injury.

Read the instruction manual fully. Do not attempt any operation until you have read and understood this manual.

Most important you must know how to safely start and stop this machine, especially in an emergency.

Keep the work area tidy and clean. Attempting to clear clutter from around the machine during use will reduce your concentration. Mess on the floor creates a trip hazard. Any liquid spilt on the floor could result in you slipping.

Find a suitable location. If the machine is bench mounted; the location should provide good natural light or artificial lighting as a replacement. Avoid damp and dust locations as it will have a negative effect on the machine's performance. If the machine is portable; do not expose the tool to rain. In all cases do not operate power tools near any flammable materials.

Beware of electric shock. Avoid contact with earthed surfaces; because they can conduct electricity if there is an electrical fault with the power tool. Always protect the power cable and route it away from danger.

Keep bystanders away. Children, onlookers and passers by must be restricted from entering the work area for their own protection. The barrier must extend a suitable distance from the tool user.

Unplug and house all power tools that are not in use. A power tool should never be left unattended while connected to the power supply. They must be housed in a suitable location, away locked up and from children. This includes battery chargers.

Do not overload or misuse the tool. All tools are designed for a purpose and are limited to what they are capable of doing. Do not attempt to use a power tool (or adapt it in any way) for an application it is not designed for. Select a tool appropriate for the size of the job. Overloading a tool will result in tool failure and user injury: This covers the use of accessories.

Dress properly. Loose clothing, long hair and jewellery are all dangerous because they can become entangled in moving machinery: This can also result in parts of body being pulled into the machine. Clothing should be close fitted, with any long hair tied back and jewellery and neck ties removed. Footwear must be fully enclosed and have a nonslip sole.

Wear personal protective equipment (PPE). Dust, noise, vibration and swarf can all be dangerous if not suitably protected against. If the work involving the power tool creates dust or fumes; wear a dust mask. Vibration to the hand, caused by operating some tools for longer periods must be protected against. Wear vibration reducing gloves and allow long breaks between uses. Protect against dust and swarf by wearing approved safety goggles or a face shield. These are some of the more common hazards and preventions; however, always find out what hazards are associated with the machine/work process and wear the most suitable protective equipment available.

Do not breathe contaminated air. If the work creates dust or fumes; connect the machine (if possible) to an extraction system either locally or remotely. Working outdoors can also help if possible.

Move the machine as instructed. If the machine is hand held, do not carry it by the power supply cable. If the product is heavy; employ a second or third person to help move it safely or use a mechanical device. Always refer to the instructions for the correct method.

5. HEALTH & SAFETY INFORMATION

Do not overreach. Extending your body too far can result in a loss of balance and you falling. This could be from a height or onto a machine and will result in injury.

Maintain your tools correctly. A well maintained tool will do the job safely. Replace any damaged or missing parts immediately with original parts from the manufacturer. As applicable; keep blades sharp; moving parts clean, oiled or greased; handles clean; and emergency devices working.

Wait for the machine to stop. Unless the machine is fitted with a safety brake; some parts may continue to move due to momentum. Wait for all parts to stop; then unplug it from the power supply before making any adjustments, carrying out maintenance operations or just finishing using the tool.

Remove and check setting tools. Some machinery requires the use of additional tools or keys to set, load or adjust the power tool. Before starting the power tool always check to make certain they have been removed and are safely away from the machine.

Prevent unintentional starting. Before plugging any machine in to the power supply, make sure the switch is in the OFF position. If the machine is portable; do not hold the machine near the switch and take care when putting the machine down; that nothing can operate the switch.

Carefully select an extension lead. Some machines are not suitable for use with extension leads. If the tool is designed for use outdoors; use an extension lead also suitable for that environment. When using an extended lead, select one capable of handling the current (amps) drawn by the machine in use. Fully extend the lead regardless of the distance between the power supply and the tool. Excess current (amps) and a coiled extension lead will both cause the cable to heat up and can result in fire.

Concentrate and stay alert. Distractions are likely to cause an accident. Never operate a power tool if you are under the influence of drugs (prescription or otherwise), including alcohol or if you are feeling tired. Being disorientated will result in an accident.

Have this tool repaired by a qualified person. This tool is designed to conform to the relevant international and local standards and as such should be maintained and repaired by someone qualified; using only original parts supplied by the manufacturer: This will ensure the tool remains safe to use.

5.2 ADDITIONAL SAFETY INSTRUCTIONS FOR IMPACT WRENCHES

Important: Draper Tools Limited recommends that this machine should not be modified or used for any application other than that for which it was designed. If you are unsure of its relative applications do not hesitate to contact us in writing and we will advise you.

- Power tools shall not be used in potentially explosive atmospheres unless specifically designed for that purpose.
- Unexpected tool movement due to reaction forces or breakage of inserted tool or reaction bar may cause injuries.
- Power tools shall be isolated from the energy source before changing or adjusting the inserted tool.

Warning!

- There is a risk of crushing by torque between a reaction bar and the workpiece.
- There is a risk of loose clothing, hair etc., being caught in the rotating spindle of the power supply tool.
- There is a risk of being injured if hands are not kept away from the reaction bar, specially observed when unscrewing in confined work spaces.
- There is a risk of being injured if hands are not kept away from the impact socket.

5. HEALTH & SAFETY INFORMATION

- There is a risk of danger to persons from high speed splinters being emitted from impact wrenches in the case of socket failure.

Warning! Only use properly hardened impact sockets with this machine.

- Unexpected direction of inserted tool movement can cause a hazardous situation.
- Use only sockets and adaptors which are in good condition and are intended for use with impact wrenches.
- Adopt a suitable posture to counteract normal or unexpected movement of the power tool due to reaction forces from the power assembly tool.
- Impact wrenches are not torque wrenches and are not designed or capable of installing fasteners to a specified torque. For fasteners requiring a specific torque, install the fastener to well below the required value then complete the task with a hand torque wrench to avoid damaging the fastener or workpiece.
- Ensure the anvil ring is correctly maintained and if damaged or missing, is replaced immediately before work commences. Missing or damaged anvil rings may lead to sockets detaching from the wrench while rotating at high speed.
- Only use accessories specifically hardened for impact use. Do not use standard chrome type hand tool sockets as they will shatter and splinter causing injury.
- Do not modify this impact wrench in any way.
- When starting or finishing the removal and installation of fasteners there is a risk of crushing between the tool and the workpiece due to sudden movement or reaction forces.

5.3 RESIDUAL RISK

Important note: Although the safety instructions and operating manuals for our tools contain extensive instructions of safe working with power tools, every power tool involves a certain residual risk which can not be completely excluded by safety mechanisms. Power tools must therefore always be operated with caution!

5.4 SAFETY INSTRUCTIONS FOR BATTERY PACKS/CHARGERS

1. The charger is for **indoor** use only.
2. Prior to plugging the charger in to the supply, check that the plug and the cable are in good repair. If either are damaged, have the defective item replaced immediately by a suitably qualified person. If the casing of the battery charger is damaged, it is good policy to have the charger checked over by a suitably qualified person.
3. Only use a correctly rated mains outlet to provide power, do not plug into site generators, engine generators or D.C. sources. Do not use a mains socket outlet that is not switched.
4. Only use the charger that was supplied with the battery pack, and vice versa.
5. Do not attempt to charge battery packs that are too hot (over 30°C) or too cold (under 5°C); if these conditions apply set the battery aside to "normalise" before proceeding with the charging operation.
6. Set up the charger and cable in a safe place where it won't be knocked, tripped over, stepped on, etc. and where it is well ventilated; make sure the ventilation slots in the charger case are not obstructed.
7. Inspect the battery pack for damage; if it is undamaged, plug it into the charger, ensuring the correct orientation. (Most chargers and batteries have 'keys' etc, to make sure the battery is not inserted incorrectly, if you are having to 'force' the battery into the charger, the chances are you have it the wrong way round, check and try again). If the battery has been dropped, it may have irreversible internal damage – this is not covered by the warranty.

5. HEALTH & SAFETY INFORMATION

8. Switch the charger on and check that the correct indicators illuminate, allow the battery pack to charge (see the specific instructions for your charger). Once charging is complete, switch the charger off, remove the battery pack and store, repeat the procedure if you have more than one battery to charge. Note that some RAPID chargers require a "rest" period between charges, read the instruction manual concerning your specific charger to see if this is the case. After charging is complete, unplug the charger from the socket outlet by pulling on the plug. Do not pull on the cable. Store the charger in a dry secure place.
9. If, when the charger was switched on, the correct indications did not occur, leave for two or three minutes to allow the charger to stabilise; if the correct indications occur, allow the charging cycle to proceed as normal. If no indication appears at all, switch off, remove the battery pack, unplug the charger, check that the charger contacts and the battery contacts are clean and repeat the process; if there is still no indication, switch off, remove the battery pack, unplug the charger and check the fuse. If the fuse is blown, replace and repeat the process; if the fuse blows again, or if the fuse was intact, attempt no further action. Refer the charger to a suitably qualified person for assessment/repair.
10. Before charging the battery, read the instructions.
11. Batteries are for indoor use. Do not expose to rain.
12. Only charge Draper battery (83079) in its designated charger (83077).
13. Do not charge any other batteries in the charger. Any other application is considered misuse.
14. The battery must be removed from the appliance before it is recycled.
15. The charger must be disconnected from the supply mains when removing the battery.
16. The battery must be disposed of in-line with local authority procedures.
17. Do not use any batteries other than 83079 in this product.
18. Do not crush, open or burn the battery. Exposure to potentially harmful materials may occur.
19. In case of fire use CO₂ dry chemical extinguisher.
20. Do not expose to high temperatures >50°C. The battery may degrade at high temperatures.
21. The battery must only be charged by Draper charger 83077.

5.5 CONNECTION TO THE POWER SUPPLY (CHARGER)

Make sure the power supply information on the machine's rating plate are compatible with the power supply you intend to connect it to.

This charger comes supplied with a UK standard 3 pin plug. It is designed for connection to a domestic power supply rated at 230V AC.

This charger is Class II[†] and is designed for connection to a power supply matching that detailed on the rating label and compatible with the plug fitted.

If an extension lead is required, use an approved and compatible lead rated for this appliance. Follow all the instruction supplied with the extension lead.

[†]Double insulated : This product requires no earth connection as supplementary insulation is applied to the basic insulation to protect against electric shock in the event of failure of the basic insulation.

This product requires no earth connection as supplementary insulation is applied to the basic insulation to protect against electric shock in the event of failure of the basic insulation.

Apart from replacing the fuse in the plug, no other electrical work is recommended on this impact wrench.

6. TECHNICAL DESCRIPTION

6.1 IDENTIFICATION



① ½" Square drive (male) anvil.

② Variable speed trigger switch.

③ Hand grip.

④ Gearbox.

⑤ Protective rubber bumper.

⑥ Forward/reverse drive selector switch.

⑦ Belt clip.

⑧ Battery charger.

⑨ Charger cable and plug.

⑩ 20V Battery pack.

⑪ Battery release/retention button.

7. UNPACKING & CHECKING

7.1 PACKAGING

Carefully remove the product from the packaging and examine it for any sign of damage that may have happened during shipping. Lay the contents out and check them against the parts shown below. If any part is damaged or missing; please contact the Draper Help Line (the telephone number appears on the Title page) and do not attempt to use the product.

The packaging material should be retained at least during the guarantee period: in case the machine needs to be returned for repair.

Warning! Some of the packaging materials used may be harmful to children. Do not leave any of these materials in the reach of children.

If any of the packaging is to be thrown away, make sure they are disposed of correctly; according to local regulations.

7.2 WHAT'S IN THE BOX?

As well as the impact wrench and battery charger, there are several parts not fitted or attached to it.



⑩ 2 × 20V Battery packs (Draper Stock No.82983)*.

⑫ 4 × Impact sockets, sizes; 17mm, 19mm, 21mm and 23mm.

*Stock No.01031 is supplied with 1 × 20V battery pack.

8. PREPARING THE IMPACT WRENCH

8.1 BATTERY PACK CHARGING FIGS. 1 – 2

This product is supplied with an 1 hour 'fast' charger solely designed for charging the battery packs supplied with this machine.

Once connected to the mains supply, recharging of the battery can be left generally unsupervised requiring minimal attention. Complex circuit construction monitors the battery condition adjusting the recharge current to suit. When the recharge cycle is complete and to maintain the full capacity a low output current will continue as required.

Warning! Check the condition of the charger and battery prior to each charge. **If there is any sign of damage then do not commence charging, seek advice from Draper Tools.**

To charge the battery pack (10), it must first be removed from the tool.

To release the battery pack:

- Press the battery release button (11) and gently slide the battery pack off (Fig.1).
- Plug the battery charger (8) unit into a 230V/AC 13amp, three pin supply socket.
- The green LED (8.1) will illuminate to show the charger has power.
- Slide the battery into the charger (the charger has raised ribs which only allows the battery to fit into the charger one way).
- After a few seconds delay, the red LED (8.2) will illuminate to show the battery is being charged.
- When the battery is fully charged, the green LED (8.1) will illuminate.

Warning! If any of the following occurs, unplug the charger from the power supply socket outlet and replace the battery pack.

- None of the indicators lights are illuminated.
 - Disconnect battery charger from the power supply.

Caution: Do not pull the plug out of the power supply by pulling on the cord. Make sure to grasp the plug when removing from power supply to avoid damaging the cord.

To remove the battery from the battery charger:

- Supporting the battery charger with hand, pull out the battery from the battery charger.

Caution: If the battery charger has been in continuous use it will be hot. Once the charging has been completed, leave the charger 15 minutes to cool until next use.



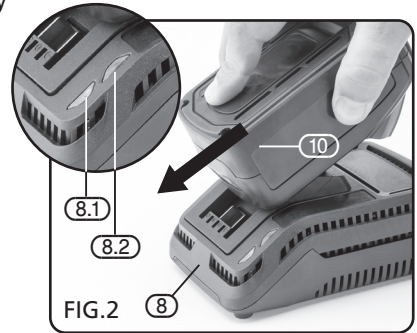

If the battery is charged when it is warm due to battery use or exposure to sunlight, the battery will not be recharged. In such a case, let the battery cool before charging.



8. PREPARING THE IMPACT WRENCH

8.2 BATTERY PACK CHARGE STATUS – FIG. 3

To display the amount of charge left in the battery pack press the charge level indicator button (13).

Charge level indicator	Amount of charge remaining
	0 – 10%
	10 – 25%
	25 – 50%
	50 – 75%
	75 – 100%



8.3 BATTERY LIFE EFFICIENCY AND CHARGING ADVICE

- Recharge the batteries before they become completely exhausted.
- When you feel that the power of the tool becomes weaker, stop using the tool and recharge the battery. If you continue to use the tool and exhaust the electric current, the battery may become damaged.
- Avoid recharging at high temperatures.
A rechargeable battery will be hot immediately after use. If such a battery is recharged immediately after use, its internal chemical substance will deteriorate, and the battery life will be shortened. Leave the battery and recharge it after it has cooled for a while.
- In order to increase charging capacity and the useful life of battery pack, please discharge the remaining power first.
 - Re-charge the battery pack for 24-hours whenever the user charges the battery pack for the first time or re-uses the battery pack after more than a months storage.
- The battery should only be used and/or charged when battery temperature is between 5°C and 30°C.
- The battery needs to be warmed-up or cooled down in order to prevent damage to the batteries internal components,

Note: If battery is too hot or too cold, allow it to 'normalise' before use or charging.

Note: Failure to warm up or cool down a battery could result in serious damage to the battery, charger and user.

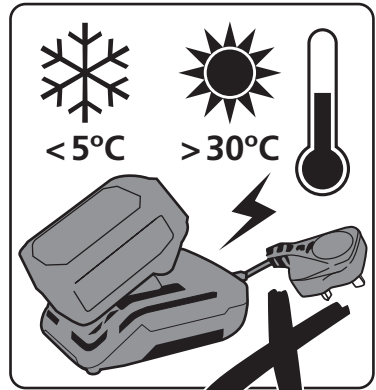

9. BASIC OPERATION

9.1 INSTALLING AND REMOVING SOCKETS – FIGS. 4 – 5

This wrench is supplied with a ½" Square Drive (1).

Note: Never use any sockets or accessories that are not hardened for impact use.

To fit a socket:

- Roughly align the hole in the impact socket (12.1) with the sprung loaded ball detent (1.1) located on the square drive anvil (1).
- Push fit the socket over the anvil. The mechanism holds the socket securely in place.

To remove a socket:

- Pull the socket away from the anvil to remove.

Note: Extra effort may be required when fitting and removing brand new sockets on their initial usage.

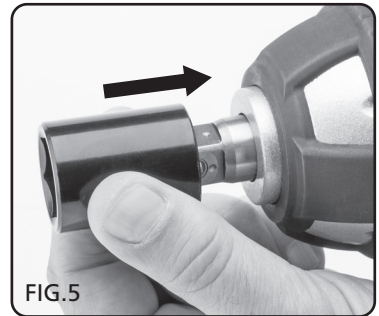
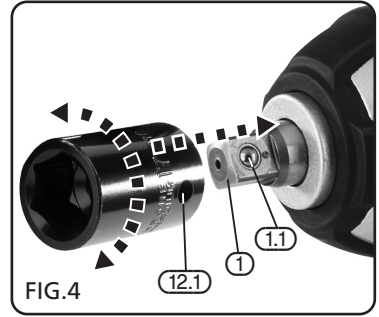

9.2 ROTATIONAL DRIVE SELECTION – FIG. 6

The forward/reverse drive selector switch (6) determines the direction of rotation of the drive, i.e. clockwise or anticlockwise.

To alter the direction of rotation:

- Stop the machine and push switch (6) to the left or right.
- When the direction switch is pushed to the left, the drive will rotate clockwise.
- When the switch is pushed to the right, the drive will rotate anticlockwise.
- Before operation, check that the switch is set in the required position. Do not change the direction of rotation until the wrench comes to a complete stop.
- When the wrench is not in use move the direction switch to the neutral position (the middle setting) to lock the trigger out.

Note: Failure to use the neutral position may activate the trigger inadvertently. This inadvertent operation may cause the wrench to become damaged.

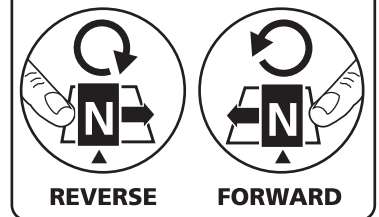

9. BASIC OPERATION

9.3 VARIABLE SPEED TRIGGER – FIG. 7

When the trigger (2) is depressed, the drive will rotate (provided the direction switch (6) is set in the forward or reverse position). This trigger switch is electronic which enables the user to vary the speed continuously.

- The speed varies according to how far the trigger switch is depressed.
- The further it is depressed, the faster the drive spindle will rotate.
- The lighter it is depressed, the slower it will rotate.

Note: It may be necessary to initially release fixings with a hand tool prior to using the impact wrench.

Note: Always tighten fixings to the correct torque as indicated by the manufacturer using a calibrated torque wrench. Failure to do so may result in the fixing becoming damaged or insufficiently tightened.

Note: This product is equipped with an electric brake.

9.4 BELT CLIP – FIG. 8

The spring steel belt clip (7) is convenient for hanging the drill temporarily. The clip can be installed on either side of the tool.

To install the clip:

- Locate the clip (7) in position and fasten with screw (7.1) supplied, take care to not overtighten and strip the thread.

9.5 OPERATION

Proper fastening torque is determined by the kind of fastening, the size of the fastening or the material or workpiece.

- It is advisable to perform a test operation to determine the proper fastening time for the fastening you are using.
- Hold the wrench in straight alignment to the fastening.
- Depress the wrench and use for the required amount of time.
- After fastening, always check the torque with an appropriate torque wrench.

Note: Do not use this tool to install wheel nuts on wheels without a torque limiting device. Doing so could result in galled or broken nuts.

Note: Using a universal joint or extension bar may reduce the fastening force of the impact wrench and require longer fastening time.

Note: Using an impact wrench creates heat. The metal housing at the front of the wrench will become hot. In certain circumstances, the force required to tighten or remove fixings may cause the fixings themselves to become very hot! Wear suitable gloves to prevent burns.

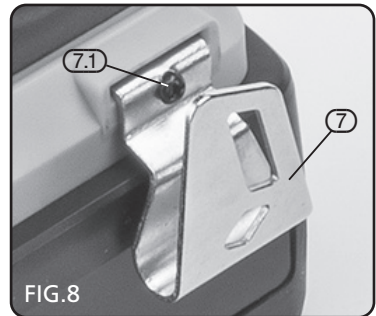

10. MAINTENANCE AND TROUBLESHOOTING

10.1 MAINTENANCE

Regular inspection and cleaning reduces the necessity for maintenance operations and will keep your tool in good working condition.

The motor must be correctly ventilated during tool operation. Avoid blocking the air inlets and vacuum the ventilation slots regularly.

10.2 TROUBLESHOOTING

Note: Remove the plug from the socket before carrying out adjustment, servicing or maintenance.

Problem	Possible Cause	Remedy
Motor does not start.	1. Battery no charge.	1. Re-charge battery.
	2. Battery faulty or damaged.	2. Replace battery.
	3. Blown fuse in charger plug.	3. Replace fuse.
	4. Brushes worn.	4. Have carbon brushes in motor replaced – Stock No.01076.
Motor runs, but slowly/ losing power.	1. Battery no charge.	1. Re-charge battery.
	2. Battery faulty or damaged.	2. Replace battery.

10.3 REPLACEMENT ACCESSORIES

Item	Stock No.	Part No.	Voltage
Battery pack.	83079.	CB20A.	20V (3.0Ah).
Charger.	83077.	BC20A.	230V~50Hz 1hr 'fast' charger.
Carbon brushes.	01076.	YCIW20LISF1	

11. DISPOSAL

11.1 DISPOSAL

At the end of the machine's working life, or when it can no longer be repaired, ensure that it is disposed of according to national regulations.

Contact your local authority for details of collection schemes in your area.

In all circumstances:

- Do not dispose of power tools with domestic waste.
- Do not incinerate.
- Do not abandon in the environment.
- Do not dispose of WEEE* as unsorted municipal waste.



11.2 HEALTH AND SAFETY FOR BATTERIES

General: Do not put in fire or mutilate – cells may burst or release toxic materials.

Do not short circuit cells, may cause burns.

The battery must be removed from the appliance before it is scrapped.

The battery is to be disposed of safely.

11.3 DISPOSAL

Do not mutilate batteries, corrosive electrolyte will be released.

Do not incinerate – danger of explosion and release of toxic fumes.

Do not dispose of batteries or cells in a charged condition.

Expired batteries must be recycled/disposed of in accordance with the appropriate regulation or legislation. They should be returned to your local warranty agent/stockist.

* Waste Electrical & Electronic Equipment.

12. EXPLANATION OF SYMBOLS

12.1 EXPLANATION OF SYMBOLS



Warning!
Read the instruction manual.



Warning!
Wear eye protection.



Warning!
Wear ear defenders.



Class II construction
(Double insulated).



WEEE
Do not dispose of Waste Electrical
& Electronic Equipment in with
domestic rubbish.



Li-ion

Lithium-ion product.
Refer to your local authority for
advice on disposal and recycling.



**Do not incinerate
or throw onto fire.**



For indoor use only.
Do not expose to rain.



**Short-circuit-proof safety isolating
transformer.**



Fuse.



Polarity indication.



Rated voltage.

- **DRAPER TOOLS LIMITED,**
Hursley Road, Chandler's Ford,
Eastleigh, Hampshire. SO53 1YF. U.K.
- **Help Line:** (023) 8049 4344
- **Sales Desk:** (023) 8049 4333
- **General Enquiries:** (023) 8026 6355
- **Service/Warranty Repair Agent**
For aftersales servicing or warranty repairs, please contact the Draper Tools Help Line for details of an agent in your local area.

YOUR DRAPER STOCKIST

RDCH0917

