

Thank you for purchasing a Sealey product. Manufactured to a high standard this product will, if used according to these instructions and properly maintained, give you years of trouble free performance.



IMPORTANT: PLEASE READ THESE INSTRUCTIONS CAREFULLY. NOTE THE SAFE OPERATIONAL REQUIREMENTS, WARNINGS & CAUTIONS. USE THE PRODUCT CORRECTLY AND WITH CARE FOR THE PURPOSE FOR WHICH IT IS INTENDED. FAILURE TO DO SO MAY CAUSE DAMAGE AND/OR PERSONAL INJURY, AND WILL INVALIDATE THE WARRANTY. PLEASE KEEP INSTRUCTIONS SAFE FOR FUTURE USE.

1. SAFETY INSTRUCTIONS

1.1 GENERAL SAFETY

- ❑ **WARNING!** Ensure Health & Safety, local authority, and general workshop practice regulations are adhered to when using this cabinet.
- ❑ **WARNING!** Use caution when handling and assembling the metal components. The metal may have sharp edges or corners, the use of protective gloves is recommended.
- ✓ Locate cabinet in a suitable working area and secure to a wall with suitable fasteners.
- ✓ Keep the work area clean, uncluttered and ensure there is adequate lighting.
- ✓ Keep the cabinet clean and tidy in accordance with good workshop practice.
- ✓ Keep children and unauthorised persons away from the working area.
- x **DO NOT** climb, step or stand on the cabinet shelves.
- x **DO NOT** use the cabinet for any purpose other than that for which it is designed.
- x **DO NOT** exceed the maximum weight allowance for each shelf, 45kg (100lbs).
- x **DO NOT** use in damp work areas.
- ❑ **WARNING!** The warnings, cautions and instructions referred to in this instruction manual cannot cover all possible conditions and situations that may occur. It must be understood that common sense and caution are factors which cannot be built into this product, but must be applied by the operator.



2. INTRODUCTION

Metal storage cabinet with silver-grey doors and graphite grey carcass, features three shelves, which can be easily adjusted and lock with two keys.

Overall Size (W x D x H):	762 x 381 x 1666mm
---------------------------	--------------------

3. ASSEMBLY

3.1 CONTENTS INSPECTION

Unpack all the parts and layout on the packing material. Visually inspect all panels to check for transportation damage, sometimes the corners of the panels become slightly bent, if this happen gently straighten using your hand. Some of the connecting tabs may also have closed up during transportation, prise them open with a small flat bladed screwdriver.

NOTE: It is recommended to open all the tabs up slightly to ease the assembly of the cabinet, the tabs can then be tapped back down with a rubber mallet, see Fig.2.

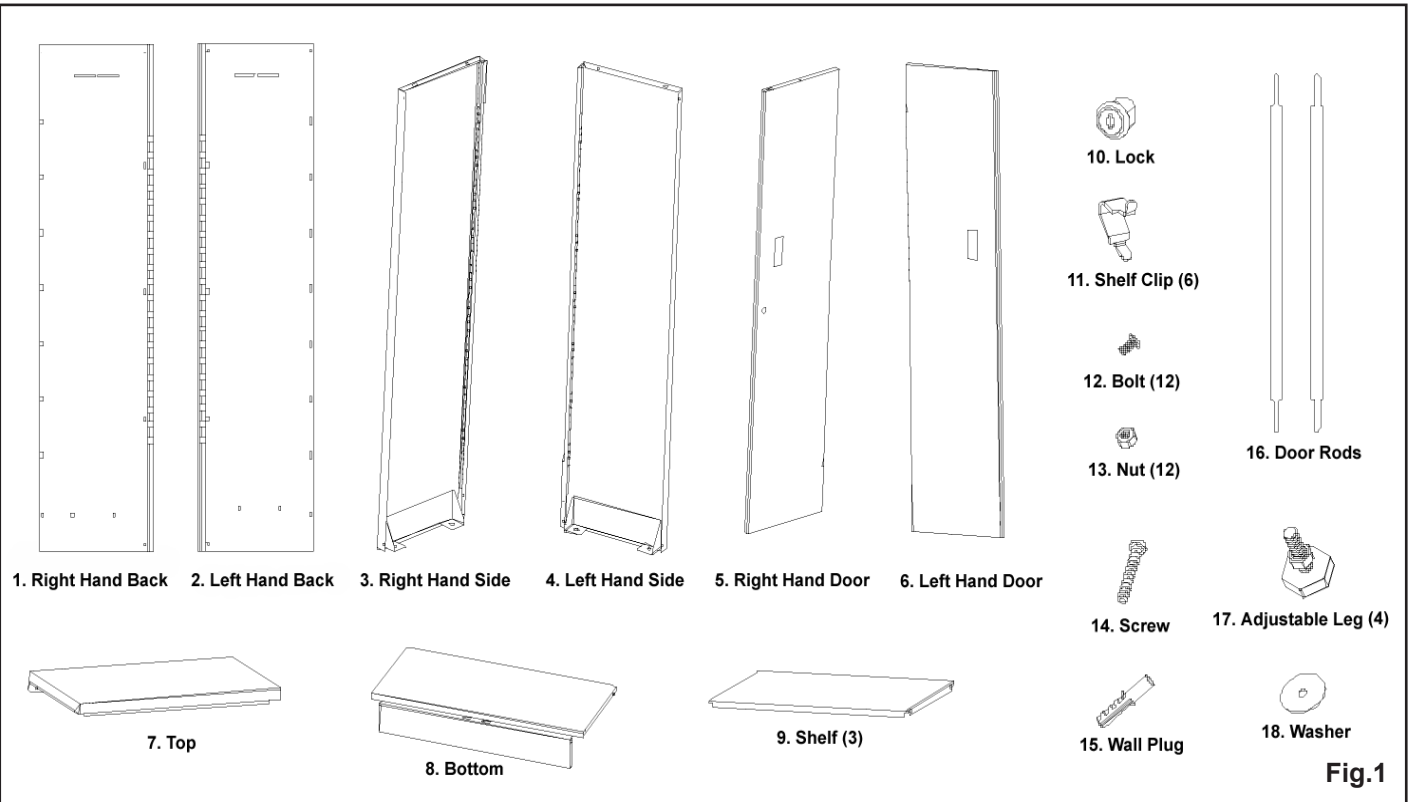

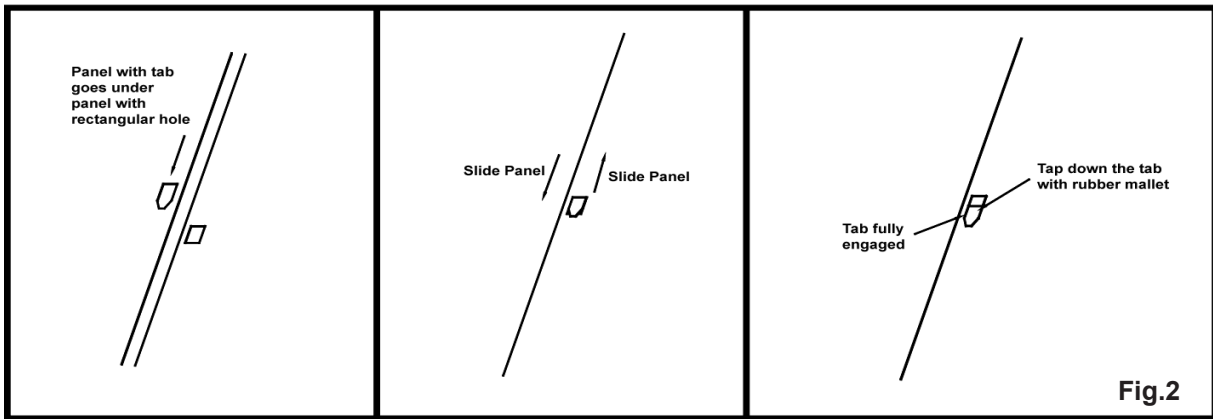

3.2 BACK ASSEMBLY (Fig.3)

- 3.2.1 Place the left and right hand back panels on a flat surface, with the flanges facing upwards.
- 3.2.2 The left hand panel should be placed underneath the right hand panel, aligning the rectangular holes with the tabs on the left hand panel, carefully slide the two panels together until the screw holes in the back panel have properly aligned.
- 3.2.3 Use a rubber mallet to tap down the tabs to ensure a tight fit.

3.3 SIDE ASSEMBLY (Fig.4)

- 3.3.1 Identify the right hand side panel, the door hinges will be at the front with the pins pointing upwards.
- 3.3.2 Place the panel underneath the back panel and align the tabs with the rectangular holes of the back assembly, slide the two panels together until the tabs are fully engaged and the top of the side panel is level with the top of the back panel.
- 3.3.3 Tap down the tabs with a rubber mallet to tighten the engagement.
- 3.3.4 Repeat the above with the left hand side panel.

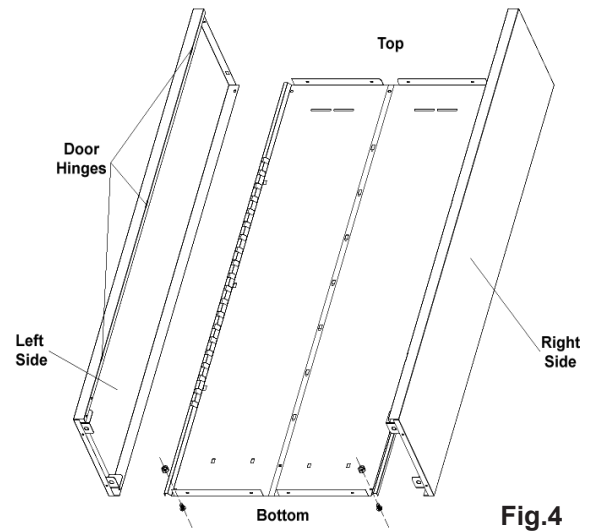
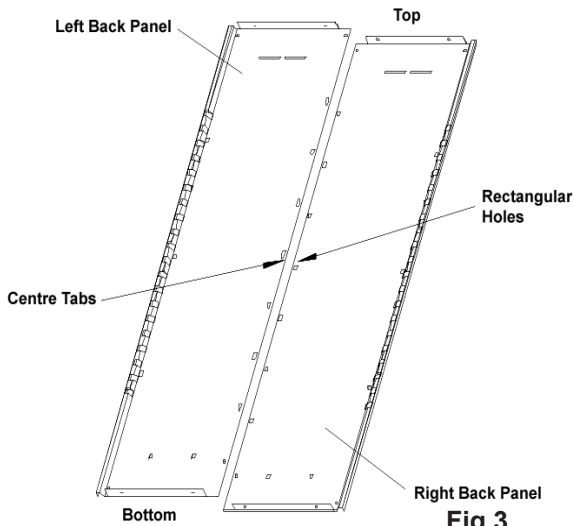

3.4 FLOOR ASSEMBLY (Fig.5)

- 3.4.1 Hold the floor panel at the front and place onto the inside of the of the back panel, align the four tabs into the rectangular holes in the back panel and slide to engage.
- 3.4.2 Align the front of the floor with the four screw holes, two holes in each side panel and secure with four M5 x 9mm bolts and M5 nuts.
- 3.4.3 Secure the back of the floor with one M5 bolt and nut as shown in Fig.5.

3.5 TOP ASSEMBLY (Fig.6)

- 3.5.1 Attach the top assembly from the back of the cabinet, it will be necessary to lift the back and side assembly slightly to allow the fitment of the top panel, align the tabs on the top section to drop into the rectangular holes in the tops of the two side panels, slide the top into position so that tabs fully engage into the holes and the screw holes align.
- 3.5.2 Secure the top with five M5 x 9mm bolts and M5 nuts as shown in Fig 6.

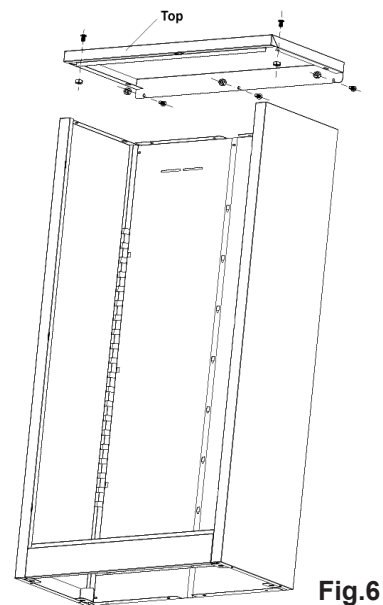
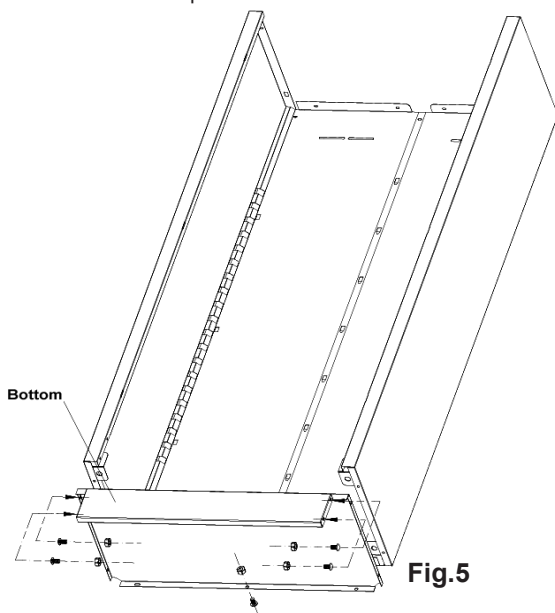

3.6 DOOR ASSEMBLY (Fig.7)

- 3.6.1 Upright the cabinet and place on a level floor. Check the cabinet for squareness, if required slacken off appropriate bolts to adjust the cabinet and then re-tighten.
- 3.6.2 Select the right hand door which is the door with the lock assembly and align the hinge with the companion hinge on the right hand side panel, slide the two hinge components together. Repeat for the left hand door.

3.7 SHELF ASSEMBLY (Fig.8)

- 3.7.1 Fit shelf clips to the front of the side panels, there are round holes located near the hinges on the side panels, locate a clip at the desired height and a corresponding clip on the opposite side. The clips are fitted by inserting the upper notch of the clip into the hole and then push and snap the lower notch in the hole below.
- 3.7.2 Select one of the shelves, the back of the shelf is denoted by having square cutouts and the front of the shelf has round cutouts, insert the shelf into the cabinet at an angle so that the back of the shelf slots into the square cut-out at the rear of the unit, then lower the front of the shelf onto the front clips. Repeat for all the other shelves.

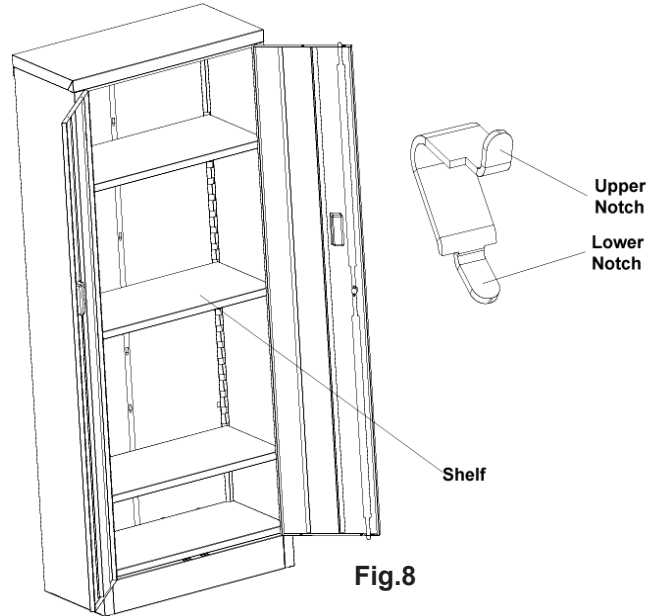
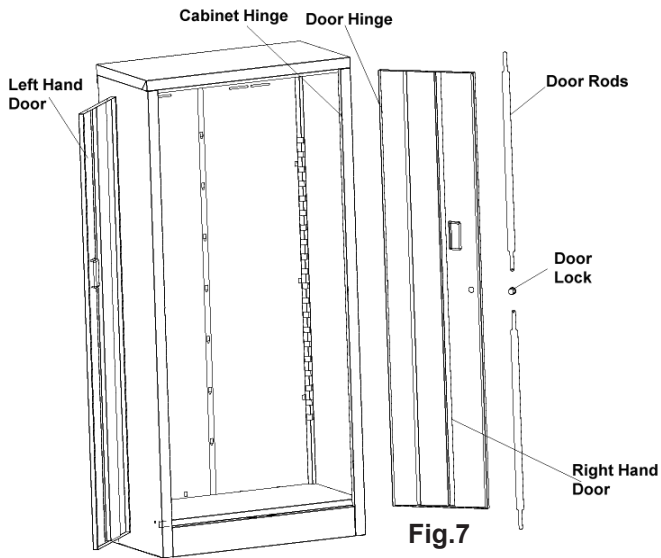

3.8 FINAL ASSEMBLY (Fig.9)

- 3.8.1 Carefully lay the unit onto its back, using the packing material to protect the unit.
- 3.8.2 Attach the four leg levellers to the bottom of the unit.
- 3.8.3 Upright the unit, position the unit where it is to be located and adjust the legs to level the unit and to ensure that the doors will open and close freely.
- 3.8.4 Use the supplied screw and washer to attach the cabinet to the wall, if it is a masonry wall alternative fasteners will be required.
- 3.8.5 **DO NOT** over-tighten the screw too much or distortion of the back of the unit will occur.
- 3.8.5 Use a mild solution of detergent and water and wipe the unit down with a soft cloth.

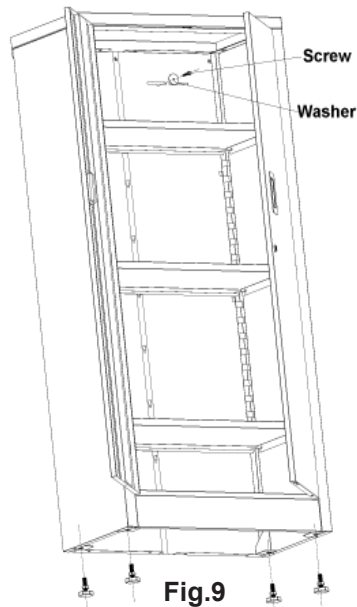

Parts support is available for this product.
To obtain a parts list and diagram please log on to www.sealey.co.uk, email sales@sealey.co.uk or phone 01284 757500

NOTE: It is our policy to continually improve products and as such we reserve the right to alter data, specifications and component parts without prior notice.
IMPORTANT: No liability is accepted for incorrect use of this product.
WARRANTY: Guarantee is 12 months from purchase date, proof of which will be required for any claim.
INFORMATION: For a copy of our catalogue and latest promotions call us on 01284 757525 and leave your full name, address and postcode.

	Sole UK Distributor Sealey Group, Bury St. Edmunds, Suffolk.	01284 757500 01284 703534	www.sealey.co.uk sales@sealey.co.uk
--	---	------------------------------	--