



INSTRUCTIONS FOR:

TOPCHEST/ROLLCAB/ADD-ON CHEST WITH BALL BEARING RUNNERS - GREEN

MODEL No's: AP26059TBRG/AP26479TBRG/AP26029TBRG

Thank you for purchasing a Sealey product. Manufactured to a high standard, this product will, if used according to these instructions, and properly maintained, give you years of trouble free performance.



IMPORTANT: PLEASE READ THESE INSTRUCTIONS CAREFULLY. NOTE THE SAFE OPERATIONAL REQUIREMENTS, WARNINGS & CAUTIONS. USE THE PRODUCT CORRECTLY AND WITH CARE FOR THE PURPOSE FOR WHICH IT IS INTENDED. FAILURE TO DO SO MAY CAUSE DAMAGE AND/OR PERSONAL INJURY AND WILL INVALIDATE THE WARRANTY. KEEP THESE INSTRUCTIONS SAFE FOR FUTURE USE.

1. SAFETY

1.1. GENERAL SAFETY

- WARNING!** Ensure Health & Safety, local authority, and general workshop practice regulations are adhered to when using these units.
- ✓ Locate the units in a suitable work area.
- ✓ Keep the work area clean, uncluttered and ensure there is adequate lighting.
- WARNING!** Use the Rollcab on level and solid ground, preferably concrete.
- ✓ Keep the units clean and tidy in accordance with good workshop practice.
- ✓ Keep children and unauthorised persons away from the work area.
- X **DO NOT** use these units for any purpose other than that for which they are designed.
- X **DO NOT** use the units outdoors.
- X **DO NOT** place the units in a damp or wet location or an area where there is condensation.
- X **DO NOT** clean the units with any solvents which may damage the surfaces or the protective coating.
- X **DO NOT** move the units with the drawers out. To avoid tipping, open one drawer at a time and close and secure all drawers whilst moving.
- X **DO NOT** step on the drawers.
- X **DO NOT** overload the drawers, weight limit per drawer is 36kg.



AP26029TBRG



AP26059TBRG



AP26479TBRG

2. INTRODUCTION

- All designed to take our modular tool trays.
- All heavy gauged steel construction and manufactured with steel inner walls for extra strength and durability.
- Heavy-duty 45mm ball bearing drawer runners provide superior performance and carry heavier loads.
- Full height rear locking mechanism, locks full-length drawers in multiple locations.
- Added security provided by tumbler locks, supplied with two folding keys.
- Rust and solvent resistant powder coat paint finish.
- The rollcab is fitted with four Ø125mm rubber wheels, two swivel castors with large toe locks and two fixed wheels.
- Topchest features heavy-duty side handles.
- Rollcab features a high, polished chrome handle for comfort and control when manoeuvring.
- Rollcab supplied with a 6mm thick top mat to protect top surface from scratching.
- Drawers feature stylish aluminium drawer pulls and non-slip liners.

3. SPECIFICATION

Model No.	AP26479TBRG	AP26059TBRG	AP26029TBRG
Overall Size W x D x H (mm):	685 x 465 x 995mm	660 x 435 x 490mm	670x 440 x 210mm
Medium Drawer (x5):	533 x 398 x 60mm	533 x 398 x 60mm	(2x) 533 x 398 x 60mm
Large Drawer (x2):	533 x 398 x 160mm		

5. ASSEMBLY

- 4.1. These units are heavy, obtain the help of at least one other person before attempting to unpack them.
(AP26479TBRG)
- 4.2. Attach the wheels to the bottom of the rollcab using 4 bolts, washers and spacers (if supplied) per wheel. The braked swivel wheels should be mounted on the same end as the handle (left hand side, fig.1).
- 4.3. Mount the side mounted handle onto the cabinet and attach with 4 bolts and washers (fig.3).
(All units)
- 4.4. AP26059TBRG or AP26029TBRG can be placed on top of AP26479TBRG, alternatively all 3 units can be assembled together as in the picture below.
- 4.5. To remove a drawer with roller sliders, pull the drawer completely out, press down the left tab and lift up the right tab, pull drawer off the slides (fig.2). To reinstall the drawer, realign with the internal drawer slide and push until it locks in place.
IMPORTANT: To avoid tipping, open one drawer at a time and close and secure all drawers whilst moving the rollcab/units.
- 4.6. Periodically lubricate wheel axles and tighten all nuts and bolts.

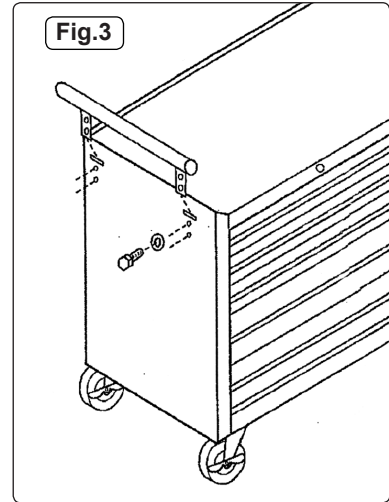
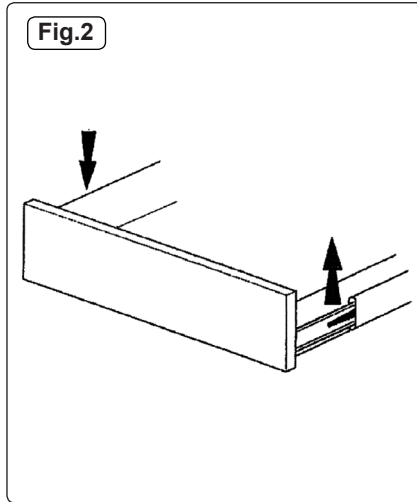
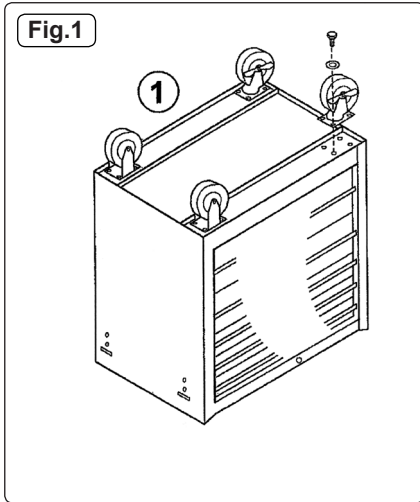

Parts support is available for this product. To obtain a listing and/or diagram, please log on to: www.sealey.co.uk, email: sales@sealey.co.uk or phone: 01284 757500



Environmental Protection.

Recycle unwanted materials instead of disposing of them as waste. All tools, accessories and packaging should be sorted, taken to a recycle centre and disposed of in a manner which is compatible with the environment.

NOTE: It is our policy to continually improve products and as such we reserve the right to alter data, specifications and component parts without prior notice.

IMPORTANT: No liability is accepted for incorrect use of this product.

WARRANTY: Guarantee is 12 months from purchase date, proof of which will be required for any claim.

INFORMATION: For a copy of our latest catalogue and promotions call us on 01284 757525 and leave your full name and address, including postcode.



Sole UK Distributor, Sealey Group,
Kempson Way, Suffolk Business Park,
Bury St. Edmunds, Suffolk,
IP32 7AR



01284 757500

01284 703534



www.sealey.co.uk

sales@sealey.co.uk