

Thank you for purchasing a Sealey product. Manufactured to a high standard this product will, if used according to these instructions and properly maintained, give you years of trouble free performance.



IMPORTANT: PLEASE READ THESE INSTRUCTIONS CAREFULLY. NOTE THE SAFE OPERATIONAL REQUIREMENTS, WARNINGS, AND CAUTIONS. USE THIS PRODUCT CORRECTLY, AND WITH CARE FOR THE PURPOSE FOR WHICH IT IS INTENDED. FAILURE TO DO SO MAY CAUSE DAMAGE AND/OR PERSONAL INJURY AND WILL INVALIDATE THE WARRANTY.

1. SAFETY INSTRUCTIONS

1.1 ELECTRICAL SAFETY

- WARNING!** It is the responsibility of the owner and the operator to read, understand and comply with the following:
 - You must check all electrical products, before use, to ensure that they are safe. You must inspect power cables, plugs, sockets and any other connectors for wear or damage. You must ensure that the risk of electric shock is minimised by the installation of appropriate safety devices. A Residual Current Circuit Breaker (RCCB) should be incorporated in the main distribution board. We also recommend that a Residual Current Device (RCD) is used. It is particularly important to use an RCD with portable products that are plugged into a supply which is not protected by an RCCB. If in any doubt consult a qualified electrician. You may obtain a Residual Current Device by contacting your Sealey dealer.
 - You must also read and understand the following instructions concerning electrical safety.
- 1.1.1 The Electricity at Work Act 1989 requires that all portable electrical appliances, if used on business premises, are tested by a qualified electrician, using a Portable Appliance Tester (PAT), at least once a year.
- 1.1.2 The Health & Safety at Work Act 1974 makes owners of electrical appliances responsible for the safe condition of those appliances and the safety of the appliance operators. If in any doubt about electrical safety, contact a qualified electrician.
- 1.1.3 Ensure that the insulation on all cables and on the appliance is safe before connecting it to the power supply. See 1.1.1 and 1.1.2 and use a Portable Appliance Tester.
- 1.1.4 Ensure that cables are always protected against short circuit and overload.
- 1.1.5 Regularly inspect power supply cables and plugs for wear or damage and check all connections to ensure that none are loose.
- 1.1.6 **Important:** Ensure that the voltage marked on the appliance matches the power supply to be used and that the plug is fitted with the correct fuse - see fuse rating at right.
- 1.1.7 **DO NOT** pull or carry the appliance by the power cable.
- 1.1.8 **DO NOT** pull the plug from the socket by the cable.
- 1.1.9 **DO NOT** use worn or damaged cables, plugs or connectors. Immediately have any faulty item repaired or replaced by a qualified electrician. When a BS 1363/A UK 3 pin plug is damaged, cut the cable just above the plug and dispose of the plug safely.
 - Fit a new plug according to the following instructions (UK only).
 - a) Connect the **GREEN/YELLOW earth wire to the earth terminal 'E'.**
 - b) Connect the **BROWN live wire to the live terminal 'L'.**
 - c) Connect the **BLUE neutral wire to the neutral terminal 'N'.**
 - d) **After wiring, check that there are no bare wires, that all wires have been correctly connected, that the cable outer insulation extends beyond the cable restraint and that the restraint is tight. Double insulated products, which are always marked with this symbol , are fitted with live (brown) and neutral (blue) wires only. To rewire, connect the wires as indicated above - DO NOT connect either wire to the earth terminal.**
- 1.1.10 Products which require more than 13 amps are supplied without a plug. In this case you must contact a qualified electrician to ensure that a suitably rated supply is available. We recommend that you discuss the installation of an industrial round pin plug and socket with your electrician.
- 1.1.11 Use of an extension cord is not recommended. If an extension reel must be used it should be fully unwound before connection. A reel with an RCD fitted is preferred since any appliance plugged into it will be protected. The cable core section is important and should be at least 2.5mm².

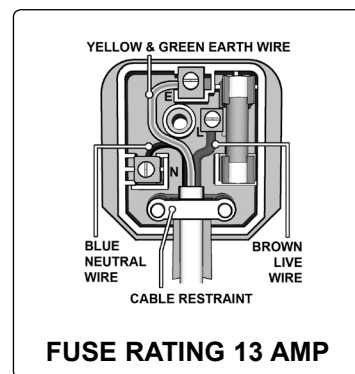

1.2 GENERAL SAFETY INSTRUCTIONS

- Familiarise yourself with the applications and limitations of the heater.
- Ensure that heater body is positioned on a firm, horizontal dry surface.
- Keep away from flammable objects/materials/surfaces. This product gets very hot during use. Use in a location where accidental contact (particularly by children) is unlikely.
- Ensure on/off switches are set to 'off' before connecting power cord to power supply.
- Ensure the heater is in good order and condition before use. If in any doubt do not use the unit and contact an electrician.
- Only use recommended attachments and parts. To use unauthorised parts may be dangerous and will invalidate your warranty.
- Check that element guard is in place, undamaged and firmly attached.
- Keep tools and other items away from the heater when it is in use.
- Keep the work area clean and clear of unnecessary items.
- Keep children and unauthorised persons away from the heater, as it gets **very hot**.
- Disconnect from mains and allow to cool before moving or attempting any cleaning or maintenance.
- DO NOT** get the heater wet or use in damp or wet locations or areas where there is condensation.
- DO NOT** locate the heater below the power outlet.
- DO NOT** remove plug from mains supply by pulling on power cord.
- DO NOT** move the heater whilst in operation or even when still warm.
- DO NOT** touch the heater elements, even when cold.
- Always** switch off heater, disconnect from power supply and allow cooling for at least **one** hour before attempting to touch heater cassette.
- DO NOT** remove safety guard whilst heater is switched on. Turn off and allow cooling (as above) before servicing.
- DO NOT** disassemble the heater for any reason. The heater must be checked by qualified personnel only.
- DO NOT** use this product to perform a task for which it has not been designed.
- DO NOT** operate heater without safety guard or elements installed.
- WARNING! If a fuse blows, ensure it is replaced with an identical fuse type and rating.**
- WARNING! If supply trips at consumer unit, ensure correct rating of supply and appliance. If further tripping occurs consult a qualified electrician.**
- DO NOT** place any object on the safety guard of the heater cassette at any time.

GENERAL SAFETY INSTRUCTIONS CONTINUED

- ❑ **WARNING!** Ensure the heater is at least 2m from any object.
- ❑ **WARNING!** Tripod leg projections could be a tripping hazard. Position with this in mind.
- x **DO NOT** leave unattended.
- ✓ When not in use, store the heater carefully in a safe, dry, childproof location.

2. INTRODUCTION & SPECIFICATION

Tripod mounted, powder coated metal construction with two ceramic heating elements provide instant heat when required. Polished reflectors maximise heat emission. Output controlled by rocker switches fitted to the frame. Supplied with 2mtr cable fitted with 13A BS1363A plug. Foldable legs for easy storage.

Min. Power:	1400W
Max. Power:	2800W
Input supply:	230V 13A
Heater dimns. (W x D x H):	360 x 120 x 380mm
Maximum height:	1560mm
Weight	14kg

3. CERAMIC ELEMENTS

DO NOT touch an element just after switching 'off' power supply. Allow to cool. Ensure that the heating elements are:

- Free of fractures and cracks and are of good general condition.
- Maximum of 1400W **each**

WARNING! There are no user serviceable components inside this heater, if an element requires replacing please return to an authorised Sealey dealer.

4. ASSEMBLY

***Heater and stand Identification Fig.1**

- | | |
|---------------------------|-----------------------------------|
| 1) *Heater Element | 7) Tripod |
| 2) *Safety Guard | 8) Spring loaded plunger |
| 3) *Heater Body | 9) Heater swivel mounting bracket |
| 4) Handle and thumb screw | 10) Adaptor and thumb screw |
| 5) *Power on Neon | 11) Hex screw and stiff nut |
| 6) *Power On/Off | 12) Rubber sleeve |

4.1 Remove contents from packaging and check against list. In the unlikely event of missing or damaged parts contact your Sealey dealer immediately.

- 4.1.1 Fit adaptor [item 10] to heater swivel bracket [item 9] with M8 hexagon head screw and hexagon stiff nut [item 11] in (fig.2). Torque screw to obtain grip without clamping the heater bracket totally. The heater angle can be adjusted about this fixing between constraints.
- 4.1.2 The tripod will be supplied assembled. Retract plunger [item 8] in (fig.1) and pull or push central column tube through sleeve until the plunger "clicks" into the next location hole. This will be the stands maximum height setting.
- 4.1.3 Slide the handle [item 4] down the central column and fix with the thumb screw through the M8 hole.
- 4.1.4 Fit the rubber sleeve [item 12] into the top of the central column in (fig.2).
- 4.1.5 Slide adaptor c/w heater into central column full depth and clamp with thumb screw.

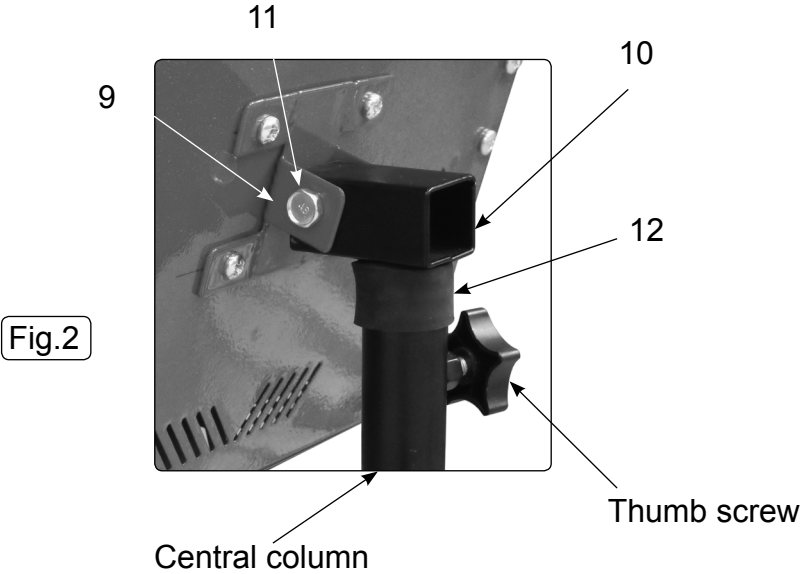
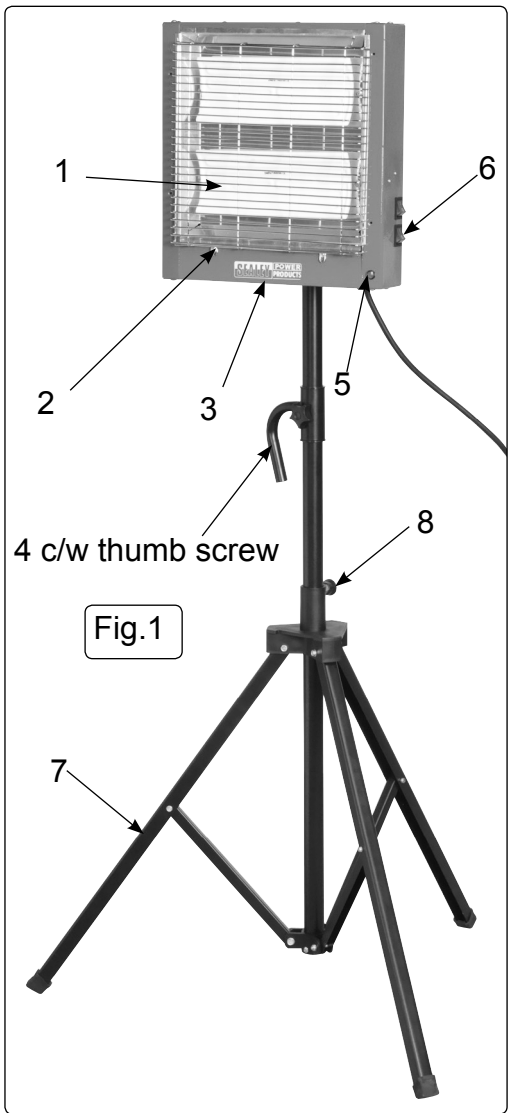

HEATER VIEWED FROM REAR

5. OPERATION

- ☐ **WARNING!** Ensure you read, understand and apply the safety instructions in Section 1 before using the heater.

NOTE! The ceramic element is fragile and therefore it is important that it is not subjected to any unnecessary shocks or vibration and is not moved when it is on or until cooled down.

- 5.1 Ensure the heater is at least 2m from any object.
 5.2 Plug in the heater and switch it on.
 5.3 The heater has the following settings: See (Fig.3).
 Position 0:0 Off position.
 Position I:0 Upper element only.
 Position 0:I Lower element only.
 Position I:I Both elements.
 5.4 When the heater is no longer required, switch off and unplug the unit.

IMPORTANT: DURING RELOCATION, THE HEATER SHOULD REMAIN SWITCHED OFF AND DISCONNECTED FROM THE POWER SUPPLY.

In the event of the heater being knocked over, a safety cut-out switch, which activates at an angle of $35^\circ \pm 10^\circ$, will disable the heater.

Follow these steps to re-start the heater.

- Switch 'off' the heater at the on/off switches. As (Fig.3).
- Disconnect the power cord from the power supply.
- Return the heater to a standing position.
- If no damage has occurred to elements, replace safety guard if applicable, re-connect power cord to the power supply and switch the heater back on.
Should the power cord require replacement, a complete wiring loom should be purchased and fitted by a suitably qualified person.

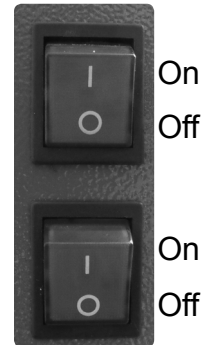

Fig.3

6. TROUBLE SHOOTING

FAULT DESCRIPTION	SUGGESTED SOLUTION
HEATER DOES NOT OPERATE	<ul style="list-style-type: none"> • Check power supply/trip. • Check for damage or misalignment. • Check all wiring connections.
OTHERS	Consult a qualified electrician or contact a <i>Sealey authorised dealer</i> .

7. MAINTENANCE

ELECTRICAL TEST, MAINTENANCE & STORAGE WARNING: THIS IS A CLASS 1 TESTED APPLIANCE

- ✓ When earth bond testing, the readings should be 0.10Ω and below.
- ✓ Disconnect from the mains and allow to cool before moving or attempting any cleaning or maintenance.
- ✓ Clean the heater and guard with a damp cloth and some mild detergent.
- ✓ When not in use, store the heater carefully in a safe, dry, childproof location.
- ✓ To replace any of the elements, contact your authorised Sealey dealer.
- ✓ Use a vacuum cleaner outside grille guard to clean dust from heater elements.
- x **DO NOT** touch the elements unless essential to do so.
- x **DO NOT** perform a flash test, as this will reduce the life of the elements.
- x **DO NOT** use abrasive cleaners or polishes on casing or guard.



Environmental Protection.

Recycle unwanted materials instead of disposing of them as waste. All tools, accessories and packaging should be sorted, taken to a recycle centre and disposed of in a manner which is compatible with the environment.



WEEE Regulations.

Dispose of this product at the end of its working life in compliance with the EU Directive on Waste Electrical and Electronic Equipment. When the product is no longer required, it must be disposed of in an environmentally protective way. Contact your local solid waste authority for recycling information.

Parts support is available for this product. To obtain a parts listing and/or diagram, please log on to www.sealey.co.uk, email sales@sealey.co.uk or telephone 01284 757500.

NOTE: It is our policy to continually improve products and as such we reserve the right to alter data, specifications and component parts without prior notice.

IMPORTANT: No liability is accepted for incorrect use of this product.

WARRANTY: Guarantee is 12 months from purchase date, proof of which will be required for any claim.

INFORMATION: For a copy of our latest catalogue and promotions call us on 01284 757525 and leave your full name and address, including postcode.



Sole UK Distributor, Sealey Group,
 Kempson Way, Suffolk Business Park,
 Bury St. Edmunds, Suffolk,
 IP32 7AR



01284 757500



www.sealey.co.uk



01284 703534



sales@sealey.co.uk