

Issue: 1
 Date: 111104

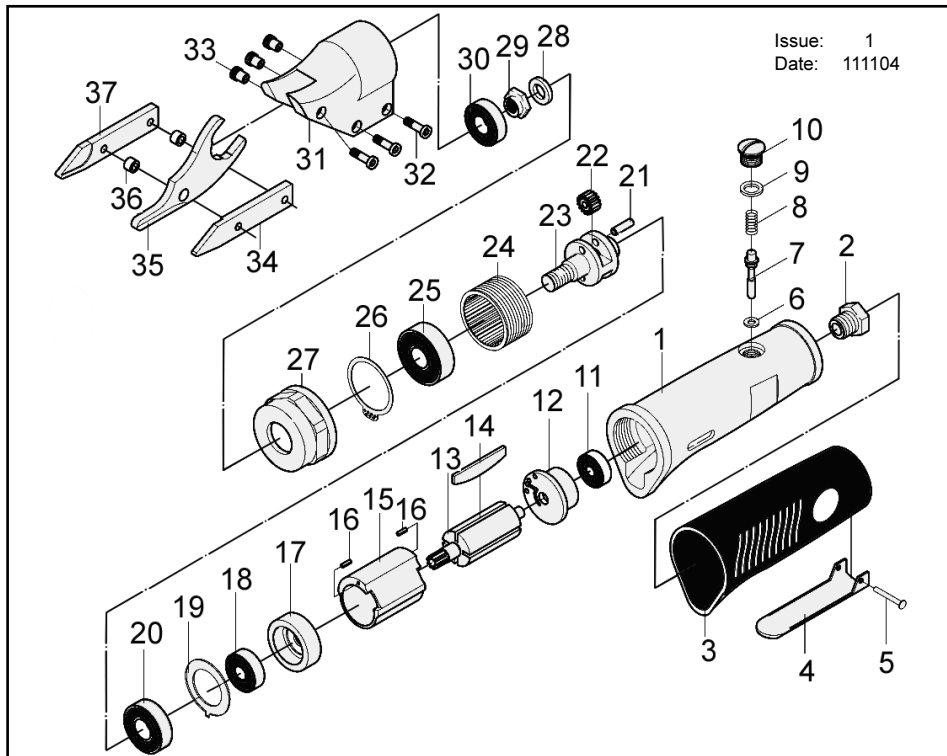

Item	Part No	Description
1	GSA53.01	HOUSING
2	GSA53.02	AIR INLET
3	GSA53.03	RUBBER GRIP
4	GSA53.04	TRIGGER
5	GSA53.05	PIN
6	GSA53.06	O-RING
7	GSA53.07	VALVE STEM
8	GSA53.08	SPRING
9	GSA53.09	O-RING
10	GSA53.10	VALVE PLUG
11	GSA53.11	BEARING
12	GSA53.12	END PLATE
13	GSA53.13	ROTOR

Item	Part No	Description
14	GSA53.14	ROTOR BLADE (PACK OF 4)
15	GSA53.15	CYLINDER
16	GSA53.16	PIN (PACK OF 2)
17	GSA53.17	FRONT PLATE
18	GSA53.18	BEARING
19	GSA53.19	WASHER
20	GSA53.20	BEARING
21	GSA53.21	PIN (PACK OF 2)
22	GSA53.22	GEAR (PACK OF 2)
23	GSA53.23	GEAR PLATE
24	GSA53.24	THREAD RING GEAR
25	GSA53.25	BEARING
26	GSA53.26	CIRCLIP

Item	Part No	Description
27	GSA53.27	CLAMP NUT
28	GSA53.28	WASHER
29	GSA53.29	ECCENTRIC NUT
30	GSA53.30	BEARING
31	GSA53.31	COVER HOUSING
32	GSA53.32	LOCK SCREW (PACK OF 3)
33	GSA53.33	LOCK NUT (PACK OF 3)
34	GSA53.34	LEFT BLADE
35	GSA53.35	CENTRE BLADE
36	GSA53.36	SPACER (PACK OF 2)
37	GSA53.37	RIGHT BLADE

NOTE: It is our policy to continually improve products and as such we reserve the right to alter data, specifications and component parts without prior notice.

IMPORTANT: No liability is accepted for incorrect use of this equipment.

WARRANTY: Guarantee is 12 months from purchase date, proof of which will be required for any claim.

INFORMATION: For a copy of our latest catalogue and promotions, call us on 01284 757525 and leave your full name and address including your postcode.