

Thank you for purchasing a Sealey product. Manufactured to a high standard this product will, if used according to these instructions and properly maintained, give you years of trouble free performance.



IMPORTANT: PLEASE READ THESE INSTRUCTIONS CAREFULLY. NOTE THE SAFE OPERATIONAL REQUIREMENTS, WARNINGS AND CAUTIONS. USE THIS PRODUCT CORRECTLY AND WITH CARE FOR THE PURPOSE FOR WHICH IT IS INTENDED. FAILURE TO DO SO MAY CAUSE DAMAGE AND/OR PERSONAL INJURY AND WILL INVALIDATE THE WARRANTY.

1. SAFETY INSTRUCTIONS

1.1 ELECTRICAL SAFETY

- ☐ **WARNING!** It is the responsibility of the owner and the operator to read, understand and comply with the following:
 - You must check all electrical products, before use, to ensure that they are safe. You must inspect power cables, plugs, sockets and any other connectors for wear or damage. You must ensure that the risk of electric shock is minimised by the installation of appropriate safety devices. A Residual Current Circuit Breaker (RCCB) should be incorporated in the main distribution board. We also recommend that a Residual Current Device (RCD) is used. It is particularly important to use an RCD with portable products that are plugged into a supply which is not protected by an RCCB. If in any doubt consult a qualified electrician. You may obtain a Residual Current Device by contacting your Sealey dealer. You must also read and understand the following instructions concerning electrical safety.
- 1.1.1 The Electricity at Work Act 1989 requires that all portable electrical appliances, if used on business premises, are tested by a qualified electrician, using a Portable Appliance Tester (PAT), at least once a year.
- 1.1.2 The Health & Safety at Work Act 1974 makes owners of electrical appliances responsible for the safe condition of those appliances and the safety of the appliance operators. If in any doubt about electrical safety, contact a qualified electrician.
- 1.1.3 Ensure that the insulation on all cables and on the appliance is safe before connecting it to the power supply. See 1.1.1 and 1.1.2 and use a Portable Appliance Tester.
- 1.1.4 Ensure that cables are always protected against short circuit and overload.
- 1.1.5 Regularly inspect power supply cables and plugs for wear or damage and check all connections to ensure that none are loose.
- 1.1.6 Important: Ensure that the voltage marked on the appliance matches the power supply to be used and that the plug is fitted with the correct fuse - see fuse rating at right.
- 1.1.7 **DO NOT** pull or carry the appliance by the power cable.
- 1.1.8 **DO NOT** pull the plug from the socket by the cable.
- 1.1.9 **DO NOT** use worn or damaged cables, plugs or connectors. Immediately have any faulty item repaired or replaced by a qualified electrician. When a BS 1363/A UK 3 pin plug is damaged, cut the cable just above the plug and dispose of the plug safely. Fit a new plug according to the following instructions (UK only).
 - a) Connect the GREEN/YELLOW earth wire to the earth terminal 'E'.
 - b) Connect the BROWN live wire to the live terminal 'L'.
 - c) Connect the BLUE neutral wire to the neutral terminal 'N'.
 - d) After wiring, check that there are no bare wires, that all wires have been correctly connected, that the cable outer insulation extends beyond the cable restraint and that the restraint is tight. Double insulated products, which are always marked with this symbol , are fitted with live (brown) and neutral (blue) wires only. To rewire, connect the wires as indicated above - **DO NOT** connect either wire to the earth terminal.
- 1.1.10 Products which require more than 13 amps are supplied without a plug. In this case you must contact a qualified electrician to ensure that a suitably rated supply is available. We recommend that you discuss the installation of an industrial round pin plug and socket with your electrician.
- 1.1.11 Use of an extension cord is not recommended. If an extension reel must be used it should be fully unwound before connection. A reel with an RCD fitted is preferred since any appliance plugged into it will be protected. The cable core section is important and should be at least 2.5mm².

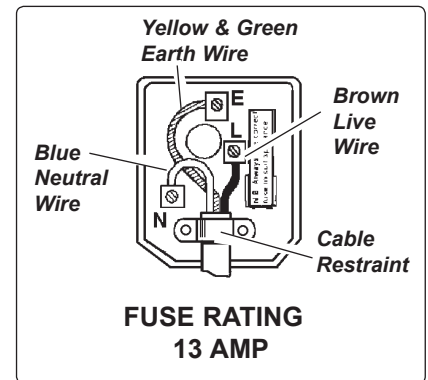

1.2 GENERAL SAFETY INSTRUCTIONS

- ☐ **WARNING!** Ensure the heater is at least 1m from any object, 30cm from the ceiling.
- ✓ The unit must be placed on a horizontal flat surface.
- ✓ Familiarise yourself with the applications and limitations of the heater.
- ✓ Ensure the heater is in good order and condition before use. If in any doubt do not use the unit and contact your Sealey dealer.
- ✓ Only use recommended attachments and parts. Using unauthorised parts maybe dangerous and will invalidate your warranty.
- ✓ Check that element guards are in place, undamaged and firmly attached.
- ✓ Keep tools and other items away from the heater when it is in use.
- ✓ Keep the work area clean and clear of unnecessary items.
- ✓ Keep children and unauthorised persons away from the heater, as it gets **very hot**.
- ✓ Disconnect from mains and allow to cool before moving or attempting any cleaning or maintenance.
- x **DO NOT** use this heater with timers or other devices which switch the heater on automatically.
- x **DO NOT** get the heater wet or use in damp or wet locations or areas where there is condensation.
- x **DO NOT** locate the heater below the power outlet.
- x **DO NOT** move the heater whilst in operation or even when still warm.
- x **DO NOT** locate the heater in an area where there are flammable gases, dust etc.
- x **DO NOT** dismantle the heater for any reason. The heater must be checked by qualified personnel only.
- x **DO NOT** use the heater to perform a task for which it has not been designed.
- ☐ **WARNING! If a fuse blows, ensure it is replaced with an identical fuse type and rating.**
- ✓ When not in use, store the heater carefully in a safe, dry, childproof location.
- ☐ **WARNING!** Never touch the element glass directly with fingers. Use a soft cloth, otherwise the tube may get damaged.
- ☐ **WARNING!** Two dark points may exist on the surface of the heating element, or the surface of the heating element may turn white during the first few minutes of operation. This is normal and will not affect the performance of the heater.

2. INTRODUCTION & SPECIFICATION

A totally dry heat, no condensation, no gas, no fumes and no smell. Reaches maximum heat output within seconds of being turned on. Highly polished aluminium reflector for maximum heat efficiency. Adjusts horizontally through 25° while mounted. Controlled by push on/off switch or remote control, allowing unit to be on full, half or low power. IFSH1809LR features two banks of 20 LED's for added lighting in evenings and dark areas. Ideal for industrial or domestic applications. Suitable for indoor and outdoor use, if weather protected (IP24 rated).

Model No	IFSH1809R	IFSH1809LR
Power:	1800W	1800W
Input supply:	230V 50Hz 13A	230V 50Hz 13A
Dimensions (W x H x D):	650 x 200 x 240mm	890 x 200 x 240mm
Minimum / Maximum Height:	1530mm / 1850mm	1530mm / 1850mm
LED Quantity:	-	40

3. MOUNTING INSTALLATION

- 3.1 **Assembly (fig.1).**
- 3.2 Insert the welded plate end of section 9 into the base 10 and secure using washer 11 and screw 12.
- 3.3 Slide section 8 onto section 9 and secure using screw 14. Slide section 5 upwards from inside of section 7, turn lock screw 6 clockwise to secure and then slide section 7 onto section 8 and secure with screw 14.
- 3.4 Insert the end of section 5 into the base of the heater 1 and secure with screw 13.
- 3.5 Align Clip 3 to the holes in sections 7 and 9 and secure with screw 4.
- 3.6 Insert cable 2 into the clips 3.

4. OPERATION

- ❑ **WARNING! Ensure you read, understand and apply the safety instructions in Section 1 before using the heater.**
- 4.1 Ensure the heater is at least 1m from any object. The heater can be tilted from 0° to 25°, set it to the required angle before switching the heater on.
- 4.2 Plug in the heater and switch it on using the ON/OFF Heat button on the base of the heater, a blue indicator light will flash indicating that the unit is in stand by mode. Press either the ON/OFF button on the control panel or on the remote to turn the heater on, the blue indicator light will be on.
- 4.3 On models fitted with LED lights, switch on the lights by using the ON/OFF Light button on the base of the unit, a blue indicator light will flash indicating that the unit is in stand by mode press the button again or the button on the remote to switch on the LED's, the blue indicator light will be on.
- 4.4 When the heater or lights are no longer required, switch off using the appropriate ON/OFF button(s) on the base and unplug the unit.
NOTE: When switching off using the remote, the heater and lights will be in stand by mode.
- 4.5 The heater has a built in tilt switch safety mechanism that switches off the unit if it is tilted beyond 25° either forwards or backwards. This prevents fire in the event of the unit being knocked over. If the unit does not turn on again when returned to the vertical, tip it approximately 25° in the opposite direction until you hear the internal switch operate. As the heater switches on return it to the vertical position.

5. MAINTENANCE

- 5.1 Make sure the heater plug is disconnected from the mains supply before any cleaning is attempted. Also allow the heater to cool completely. **DO NOT** use water, other liquids, or harsh abrasive cleaners to clean the heater. **DO NOT** touch the carbon fibre element with fingers as this may damage the tube.
 - 5.2 Clean the exterior with a soft damp cloth with some mild detergent.
 - 5.3 To replace the element or any of the lamps, contact your authorised Sealey dealer.
 - 5.4 To change the remote batteries, press down and push back the battery cover (fig.2), remove old batteries and replace with two new AAA batteries.
- ❑ **WARNING! DO NOT mix old and new batteries and dispose of old batteries in accordance with local authority regulations.**

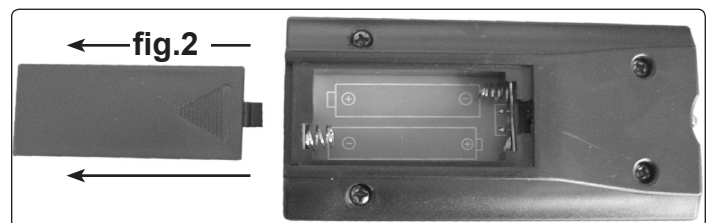
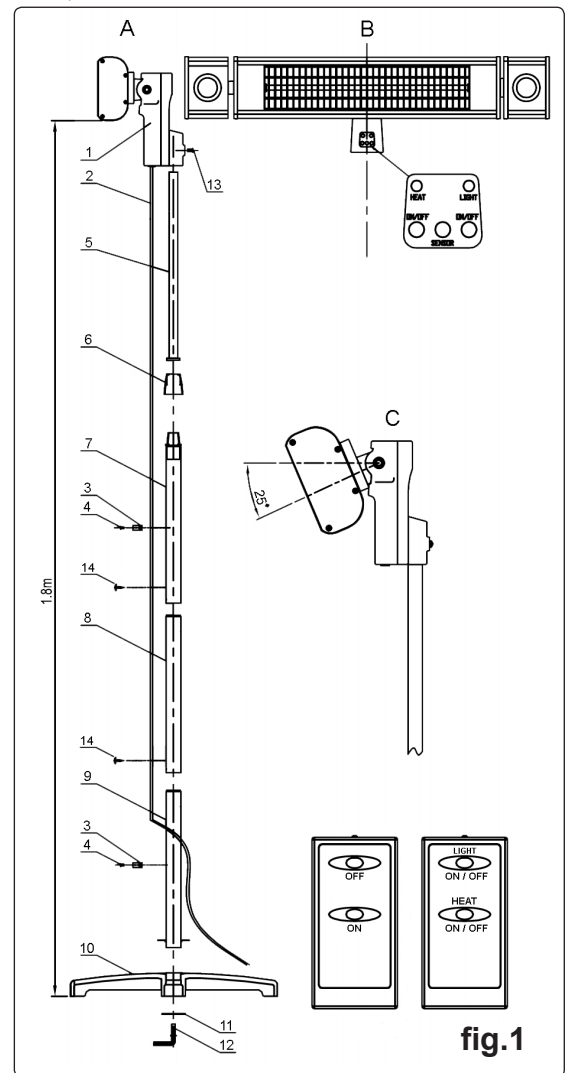

NOTE: It is our policy to continually improve products and as such we reserve the right to alter data, specifications and component parts without prior notice.

IMPORTANT: No liability is accepted for incorrect use of this product.

WARRANTY: Guarantee is 12 months from purchase date, proof of which will be required for any claim.

INFORMATION: For a copy of our latest catalogue and promotions call us on 01284 757525 and leave your full name and address, including postcode.



Sole UK Distributor, Sealey Group,
Kempson Way, Suffolk Business Park,
Bury St. Edmunds, Suffolk,
IP32 7AR



01284 757500



www.sealey.co.uk



01284 703534



sales@sealey.co.uk



EC DECLARATION OF CONFORMITY

We the sole importers into the UK, hereby declare that the equipment described below

Description and Function:..... High Efficiency Carbon Fibre Infrared Patio Heater 1800W/230V with Telescopic Floor Stand..... **+**

Model/Type:..... IFSH1809R.....

Manufacturing Date / Serial number (optional).....

Manufacturer's authorised representative within the EC: **Jack Sealey Ltd. Kempson Way, Suffolk Business Park, Bury St. Edmunds, Suffolk, IP32 7AR**

Conforms to the requirements of the following Directives, as indicated.

- 2006/42/EC Machinery Directive
- 2000/14/EC Outdoor Noise Emissions Directive
- 2006/95/EC Low Voltage Directive
- 2002/96/EC WEEE Directive
- 2004/108/EC EMC Directive
- 2002/95/EC RoHS Directive
- 93/68/EEC CE Marking Directive
- 97/23/EC Pressure Equipment Directive

And the following harmonised standard(s): **BS EN 60335 part 1 + A2: 2006** .. **BS EN 60335 part 2-30: 2009** ..

BS EN 55014 part 1: 2006 + A1: 2009 .. **BS EN 61000 part 6-3: 2007** ..

Additional technical standards and specifications (if applicable):.....
.....

Technical file compiled by: **Jack Sealey Ltd.**

Signed:..... 

Date:..... 09-Aug-2010.....

Place: Bury St.Edmunds.

Name:..... Mark Sweetman.....

Position:..... Managing Director.....

Being the responsible person appointed by the manufacturer.





EC DECLARATION OF CONFORMITY

We the sole importers into the UK, hereby declare that the equipment described below

Description and Function:..... High Efficiency Carbon Fibre Infrared Patio Heater 1800W/230V with LED Lights and Telescopic Floor Stand..... +

Model/Type:..... IFSH1809LR.....

Manufacturing Date / Serial number (optional).....

Manufacturer's authorised representative within the EC: **Jack Sealey Ltd. Kempson Way, Suffolk Business Park, Bury St. Edmunds, Suffolk, IP32 7AR**

Conforms to the requirements of the following Directives, as indicated.

- 2006/42/EC Machinery Directive
- 2000/14/EC Outdoor Noise Emissions Directive
- 2006/95/EC Low Voltage Directive
- 2002/96/EC WEEE Directive
- 2004/108/EC EMC Directive
- 2002/95/EC RoHS Directive
- 93/68/EEC CE Marking Directive
- 97/23/EC Pressure Equipment Directive

And the following harmonised standard(s): **BS EN 60335 part 1: 2006 +A2: 2009** .. **BS EN 60335 part 2-30: 2009**

BS EN 55014 part 1: 2006 + A1: 2009 .. **BS EN 61000 part 6-3: 2007**

National technical standards and specifications (if applicable):.....

Technical file compiled by: **Jack Sealey Ltd.**

Signed:..... 

Date:..... 19-Apr-2010.....

Place: Bury St.Edmunds.

Name:..... Mark Sweetman.....

Position:..... Managing Director.....

Being the responsible person appointed by the manufacturer.



Sealey Power Products, Kempson Way, Suffolk Business Park, Bury St. Edmunds, Suffolk, IP32 7AR

 01284 757500

 01284 703534

 sales@sealey.co.uk

 www.sealey.co.uk