



INSTRUCTIONS FOR: ON CAR HYDRAULIC PIPE FLARING TOOL

MODEL No: **PFT10**

Thank you for purchasing a Sealey Product. Manufactured to a high standard this product will, if used according to these instructions and properly maintained, give you years of trouble free performance.



IMPORTANT: PLEASE READ THESE INSTRUCTIONS CAREFULLY. NOTE THE SAFE OPERATIONAL REQUIREMENTS, WARNINGS AND CAUTIONS. USE THIS PRODUCT CORRECTLY AND WITH CARE, FOR THE PURPOSE FOR WHICH IT IS INTENDED. FAILURE TO DO SO MAY CAUSE DAMAGE AND/OR PERSONAL INJURY AND WILL INVALIDATE THE WARRANTY. PLEASE KEEP THESE INSTRUCTIONS SAFE FOR FUTURE USE.

1. SAFETY INSTRUCTIONS

- WARNING!** Ensure Health & Safety, local authority and general workshop practice requirements are adhered to when using this equipment. Familiarise yourself with the application and limitations, as well as the potential hazards of the kit.
- ✓ This kit is suitable for flaring copper, brass, steel or thin walled aluminium pipe.
- ✓ Maintain the kit in good condition.
- ✓ Replace or repair damaged parts. Use genuine parts only. Unauthorised parts may be dangerous and will invalidate the warranty.
- ✓ Locate the flaring tools in a suitable work area, keep the area clean and tidy and ensure there is adequate lighting.
- WARNING!** Always wear approved eye or face protection when using the flaring tools.
- ✓ Keep children and unauthorised persons away from the working area.
- x **DO NOT** use the kit for any purpose other than for which it is designed.
- x **DO NOT** use the kit if any parts are damaged or missing as this may cause failure and/or personal injury.
- x **DO NOT** allow untrained persons to use the kit.
- x **DO NOT** attempt to flare piping when you are tired, under the influence of alcohol, drugs or intoxicating medication.
- ✓ When not in use clean kit components, replace in case and store in a safe, dry, childproof area.
Remember! The safe operation of a vehicle, or other equipment, may well depend on the quality of the flare produced. Discard any flare which is mis-formed or cracked in any way.
- WARNING! The warnings, cautions and instructions discussed in this manual cannot cover all possible conditions and situations that may occur. It must be understood that common sense and caution are factors which cannot be built into this product, but must be applied by the operator.**

2. INTRODUCTION & SPECIFICATIONS

Produces accurate automotive SAE and DIN flares on 3/16" and 4.75mm pipes respectively. Small body makes it ideal for splicing in replacement sections of brake pipe on-vehicle. Features a hydraulic ram which also makes it suitable for steel pipes.

Part	Description
Dies:	3/16" SAE, 4.75mm DIN.

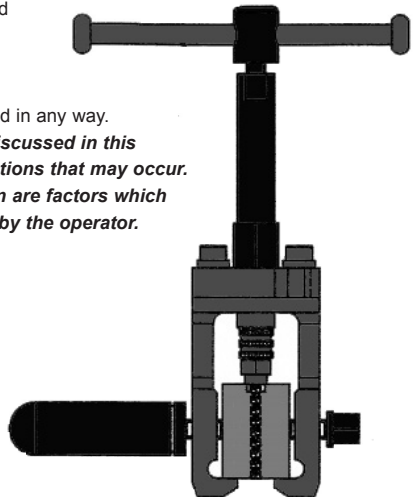

3. OPERATING INSTRUCTIONS

❑ **WARNING!** Before using the flaring kit, ensure that you have read and understood the Safety Instructions in Section 1.

3.1. The pipe end to be flared must be cut clean, square and be de-burred. Use a pipe or tube cutter (available from your Sealey dealer).

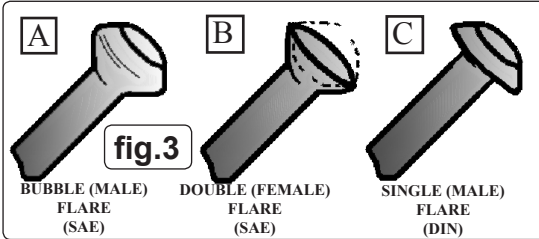

3.2. Select the clamp block. For SAE male and female flares (fig.3 A & B above) use the SAE marked side of the blocks (fig.1) and SAE marked dies. For a DIN flare (fig.3 C above) select the DIN side of the block and the DIN die.

3.3. Lay the pipe on the block, place the other half of the block on top of the pipe and insert into tool as fig.2. Ensure that the pipe is just inside the end of the block, clamp the assembly in place using lock bolt (fig.2).

3.4. **To form a Bubble (Male) flare SAE (fig.3.A).**

First select the concave SAE die (fig.4) and insert it into the locking collar on the ram (fig.5). Ensure the T-bar is fully unwound (anticlockwise).

3.4.1. Adjust the lock plate (fig.5) half way along the thread and insert the ram into the main tool body (fig.6).

3.4.2. Swivel the locking plate into position (fig.7) and tighten the ram body ensuring the die tip locates in the pipe (fig.8).

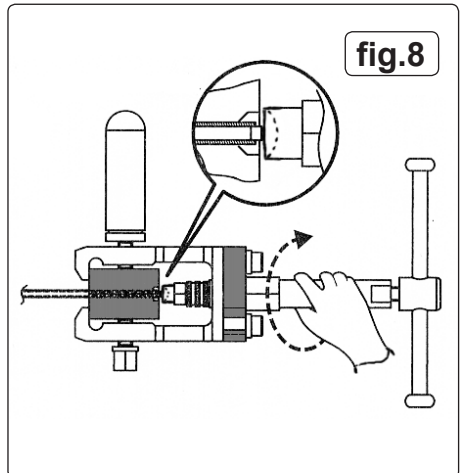
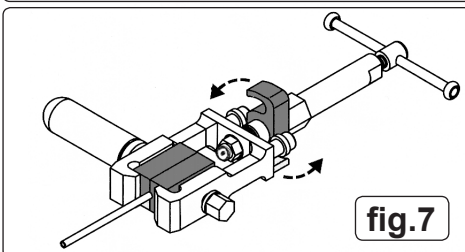
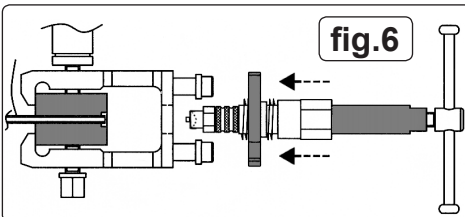
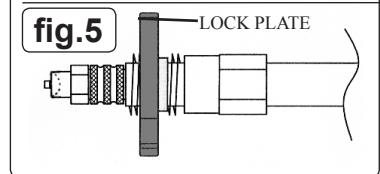
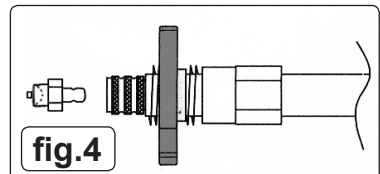
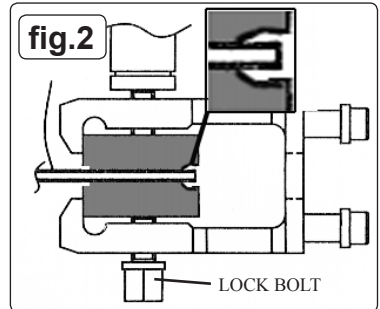
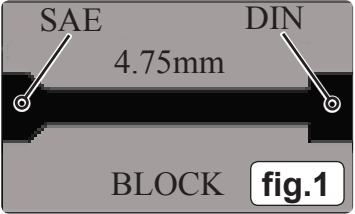

3.4.3. Rotate the T-bar clockwise forcing the die into the pipe (fig.9). Continue to turn until the resistance significantly increases, undo the T-bar a couple of turns and remove the ram assembly from the main body.

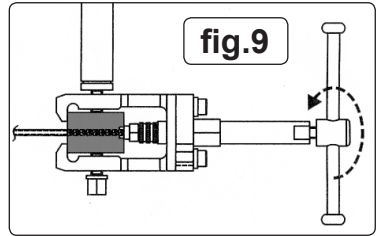

3.4.4. Remove the block and pipe from the main body (unless you wish to make a double flare (fig.3B)) and separate the block from the pipe, check that the flare has no cracks and is symmetrically formed.

3.5. To form a Double (Female) flare SAE (fig.3.B).

3.5.1. Leave the pipe in the block after completing the bubble flare.

3.5.2. Change the die to the SAE convex die (fig.10).

This will fold the top section of the bubble flare inwards to form a double flare (fig.3.B).

3.5.3. Follow the same procedure as described in 3.4 to 3.4.4.

Again, check that the flare is symmetrically formed.

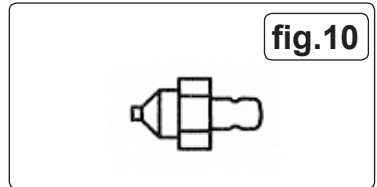

3.6. To form a Single Flare DIN (fig.3C).

3.6.1. Follow the procedures laid out in 3.4 to 3.4.4, only this time select the DIN side of the block (fig.1) and the DIN concave die.

3.7. Adaptor Driver (fig.11).

For jobs where restricted space makes use of the hydraulic ram difficult, use the 23mm adaptor driver in place of the ram.

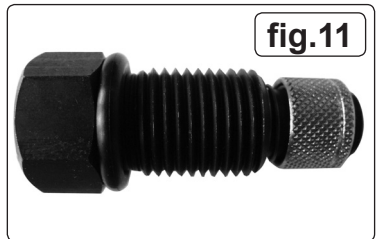

WARNING! The safe operation of a vehicle, or other equipment, may well depend on the quality of the flare produced. Discard any flare which is misformed or cracked in any way.

Parts support is available for this product. To obtain a parts listing and/or diagram, please log on to www.sealey.co.uk, email sales@sealey.co.uk or phone 01284 757500.

NOTE: It is our policy to continually improve products and as such we reserve the right to alter data, specifications and component parts without prior notice.

IMPORTANT: No liability is accepted for incorrect use of this product.

WARRANTY: Guarantee is 12 months from purchase date, proof of which will be required for any claim.

INFORMATION: For a copy of our latest catalogue and promotions call us on 01284 757525 and leave your full name and address, including postcode.



Sole UK Distributor, Sealey Group,
Kempson Way, Suffolk Business Park,
Bury St. Edmunds, Suffolk,
IP32 7AR

 01284 757500

 01284 703534



www.sealey.co.uk



sales@sealey.co.uk