

Thank you for purchasing a Sealey Product. Manufactured to a high standard this product will, if used according to these instructions and properly maintained, give you years of trouble free performance.



IMPORTANT: PLEASE READ THESE INSTRUCTIONS CAREFULLY. NOTE THE SAFE OPERATIONAL REQUIREMENTS, WARNINGS AND CAUTIONS. USE THIS PRODUCT CORRECTLY AND WITH CARE, FOR THE PURPOSE FOR WHICH IT IS INTENDED. FAILURE TO DO SO MAY CAUSE DAMAGE AND/OR PERSONAL INJURY AND WILL INVALIDATE THE WARRANTY. PLEASE KEEP THESE INSTRUCTIONS SAFE FOR FUTURE USE.

1. SAFETY INSTRUCTIONS

- ❑ **WARNING!** Ensure Health & Safety, local authority and general workshop practice requirements are adhered to when using this equipment. Familiarise yourself with the application and limitations, as well as the potential hazards of the set.
- ✓ This set is suitable for steel pipe.
- ✓ Maintain the set in good condition.
- ✓ Replace or repair damaged parts. Use genuine parts only. Unauthorised parts may be dangerous and will invalidate the warranty.
- ✓ Locate the flaring set in a suitable work area, keep the area clean and tidy and ensure there is adequate lighting.
- ❑ **WARNING!** Always wear approved eye or face protection when using the flaring tools.
- ✓ Keep children and unauthorised persons away from the working area.
- x **DO NOT** use the set for any purpose other than for which it is designed.
- x **DO NOT** use the set if any parts are damaged or missing as this may cause failure and/or personal injury.
- x **DO NOT** allow untrained persons to use the set.
- x **DO NOT** attempt to flare piping when you are tired, under the influence of alcohol, drugs or intoxicating medication.
- ✓ When not in use clean set components, replace in case and store in a safe, dry, childproof area. Remember! The safe operation of a vehicle, or other equipment, may well depend on the quality of the flare produced. Discard any flare which is mis-formed.
- ❑ **WARNING!** The warnings, cautions and instructions discussed in this manual cannot cover all possible conditions and situations that may occur. It must be understood that common sense and caution are factors which cannot be built into this product, but must be applied by the operator.

2. INTRODUCTION & SPECIFICATIONS

Patented design produces accurate automotive SAE and DIN flares on 3/16" and 4.75mm pipes respectively. Light-weight body makes it ideal for splicing in replacement sections of brake pipe on-vehicle. Suitable for steel pipes. Supplied in carry-case.

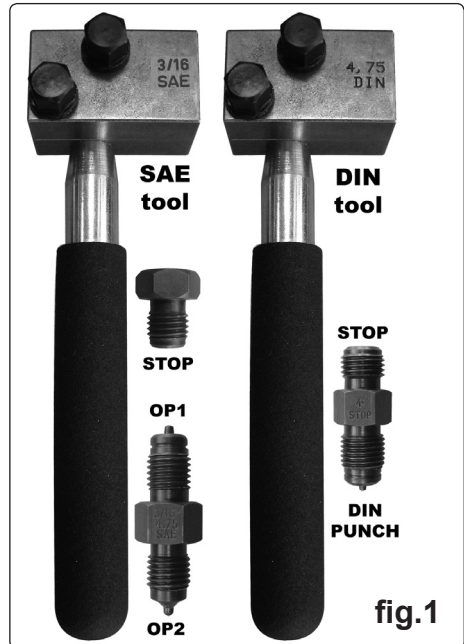

3. OPERATING INSTRUCTIONS

- ❑ **WARNING!** Ensure you are familiar with the various types of flare before using this equipment.
 - ❑ **WARNING!** Before using the flaring kit, ensure that you have read and understood the Safety Instructions in Section 1.
- 3.1 PREPARATION OF THE BRAKE PIPE**
- 3.1.1 The end of the pipe must be cut square.
 - 3.1.2 The outside edge of the pipe must be chamfered to approximately 0.25mm x 45°.
 - 3.1.3 If the pipe is plastic covered, this must be cut back for 6mm from the end of the pipe to be flared. Ensure the pipe is not scored or any metal removed during this operation. Do not use abrasive cloth.
- Note:** A spot of grease on the end of the punch helps the flare process.

3.2 CREATION OF 3/16" SAE SINGLE FLARE

- 3.2.1 Use the SAE tool, stop and double ended punch as shown in fig.1.
- 3.2.2 The stop must be screwed into the tool to within 5mm of the hexagon.
- 3.2.3 Slide the tool onto pipe.
- 3.2.4 Tighten the locking screws by hand, just enough to grip the pipe.
- 3.2.5 **IMPORTANT Do not over tighten at this stage or the stop will damage the pipe.**
- 3.2.6 Screw the stop into the tool until fully tightened. (A 16mm ratchet spanner is recommended, but not included.)
- 3.2.7 Tighten the locking screws fully to clamp the pipe. (A 10mm ratchet spanner is recommended, but not included.)
IMPORTANT If the locking screws are not tight enough then the pipe will push back during the flare process and will not produce the correct flare.
- 3.2.8 Undo and remove the stop.
- 3.2.9 Insert the OP1 end punch and tighten fully up to the hexagon in order to form the flare.
- 3.2.10 Unscrew the punch. The single flare is now complete.
- 3.2.11 Undo the locking screws and remove the tool from the pipe.



3.3 CREATION OF 3/16" SAE DOUBLE FLARE

- Firstly follow steps 3.2.1 to 3.2.10. to form a single flare.
- 3.3.1 Reverse the punch and insert the OP2 end into the tool and fully tighten up to the hexagon in order to form the flare.
 - 3.3.2 Unscrew the punch.
 - 3.3.3 Undo the locking screws and remove the tool from the pipe. The double flare is now complete.

3.4 CREATION OF 4.75mm DIN FLARE

- 3.4.1 Use the DIN tool, and double ended fitting with punch and stop as shown in fig.1.
- 3.4.2 Firstly follow steps 3.2.1 to 3.2.8 to set the pipe length.
- 3.4.3 Turn the fitting around and insert the punch end and tighten fully to form the flare.
- 3.4.4 Unscrew the punch.
- 3.4.5 Undo the locking screws and remove the tool from the pipe.

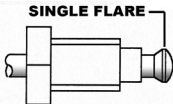
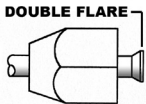
Note: After completing a flare, check that it has been correctly formed using the gauge in the end of the 3/16" stop. If the flare goes into the bore it is undersized and will need to be redone. This may be due to the tool being pushed back during the flare process.

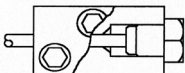
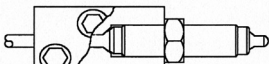
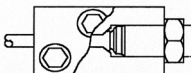
SAE FLARE		SIZE 3/16"
		
5.0mm		
	SCREW STOP INTO TOOL TO WITHIN 5MM OF HEXAGON. PLACE TOOL ON PIPE. TIGHTEN BOLTS HAND TIGHT.	
SET PIPE LENGTH		
	SCREW STOP DOWN TO HEXAGON SHOULDER THEN FULLY TIGHTEN BOLTS	
FORM FLARE		
	TO FORM A SINGLE FLARE USE OP1 END OF PUNCH	
	TO FORM A DOUBLE FLARE USE OP1 END OF PUNCH FOLLOWED BY OP2 END OF PUNCH	

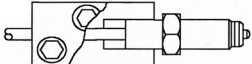
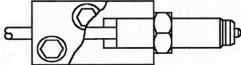
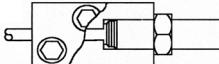
DIN FLARE	DIN FLARE
SIZE 4.75mm	
	USE STOP ON END OF PUNCH. PLACE TOOL ON PIPE. TIGHTEN BOLTS HAND TIGHT.
SET PIPE LENGTH	
	SCREW PUNCH DOWN TO HEXAGON SHOULDER FULLY TIGHTEN BOLTS
FORM FLARE	
	UNSCREW STOP END OF FITTING, REVERSE AND FULLY SCREW IN PUNCH

NOTE: It is our policy to continually improve products and as such we reserve the right to alter data, specifications and component parts without prior notice.

IMPORTANT: No liability is accepted for incorrect use of this product.

WARRANTY: Guarantee is 12 months from purchase date, proof of which will be required for any claim.

INFORMATION: For a copy of our latest catalogue and promotions call us on 01284 757525 and leave your full name and address, including postcode.



Sole UK Distributor, Sealey Group,
Kempson Way, Suffolk Business Park,
Bury St. Edmunds, Suffolk,
IP32 7AR



01284 757500



www.sealey.co.uk



sales@sealey.co.uk