

Thank you for purchasing a Sealey Product. Manufactured to a high standard this product will, if used according to these instructions and properly maintained, give you years of trouble free performance.



IMPORTANT: PLEASE READ THESE INSTRUCTIONS CAREFULLY. NOTE THE SAFE OPERATIONAL REQUIREMENTS, WARNINGS AND CAUTIONS. USE THIS PRODUCT CORRECTLY AND WITH CARE FOR THE PURPOSE FOR WHICH IT IS INTENDED. FAILURE TO DO SO MAY CAUSE DAMAGE AND/OR PERSONAL INJURY AND WILL INVALIDATE THE WARRANTY. PLEASE KEEP INSTRUCTIONS SAFE FOR FUTURE USE.

1. SAFETY INSTRUCTIONS

- ✓ Follow all workshop safety rules, regulations, and conditions when using wrench.
- ❑ **WARNING!** Disconnect from air supply before changing accessories or servicing.
- ✓ Maintain the wrench in good condition and replace any damaged or worn parts. Use *genuine parts only. Unauthorised parts may be dangerous and will invalidate the warranty.*
- ❑ **WARNING!** Check correct air pressure is maintained and not exceeded. We recommend 90psi.
- ✓ Keep air hose away from heat, oil and sharp edges. Check air hose for wear before each use and ensure that all connections are secure.
- ✓ Only use impact sockets which are specifically designed for use with an impact wrench.
- ✓ Wear approved safety eye/face shield, ear defenders and hand protection.
- ❑ **WARNING!** Due to the possible presence of asbestos dust from brake linings, when working around vehicle brake systems we recommend you wear suitable respiratory protection.
- ✓ Maintain correct balance and footing. Ensure the floor is not slippery and wear non-slip shoes.
- ✓ Keep children and non essential persons away from the working area.
- ✓ **DO NOT** use the wrench for a task it is not designed to perform.
- ❑ **WARNING! DO NOT** use wrench if damaged or thought to be faulty. (Contact Service Agent).
- x **DO NOT** use wrench unless you have been instructed in its use by a qualified person.
- x **DO NOT** carry the wrench by the air hose, or yank the hose from the air supply.
- x **DO NOT** operate wrench if you are tired or under the influence of alcohol, drugs or intoxicating medication.
- x **DO NOT** carry wrench with your hand on the power trigger in order to avoid unintentional starting.
- x **DO NOT** direct air from the air hose at yourself or others.
- ✓ When not in use disconnect from air supply and store in a safe, dry, childproof location.



2. INTRODUCTION

Lightweight wrench with heavyweight power, half the weight of traditional style 1" Sq drive air impact wrenches. Manufactured from a composite and aluminium alloy housing. Fitted with aluminium handles to minimise vibration and chill effects. Heavy hitting twin hammer mechanism gives extremely high torque output suitable for commercial and agricultural use. Ergonomically styled handle for extra control and movement, having the air intake valve at the back helps to increase control. Lever and twist controls for simple choice of speed and direction. Designed for professional workshops.

3. SPECIFICATION

Model No:	SA687
Drive:	1" Sq
Working Torque:	1800lb.ft/2448Nm
Maximum Torque:	2000lb.ft/2720Nm
Ultimate Torque:	2100lb.ft/2856Nm
Free Speed:	4500rpm
Air Consumption:	12cfm
Operating Pressure:	90psi
Air Inlet Size:	1/2" BSP
Weight:	8.8kg
Noise Power:	100.8dB.A
Noise Pressure:	111.8dB.A
Measured vibration emission value (a):	5.5m/s ²
Uncertainty value (k):	1.059m/s ²

4. PREPARING WRENCH FOR USE

4.1. Air Supply

WARNING! Ensure the air supply is clean and does not exceed 90psi while operating the wrench. Too high an air pressure and unclean air will shorten the product life due to excessive wear and may be dangerous causing damage and/or personal injury.

4.1.1. Ensure wrench air valve (or trigger) is in the "off" position before connecting to the air supply.

4.1.2. You will require an air pressure of 90psi and an air flow according to specification.

4.1.3. Drain the compressor air tank daily. Water in the air line will damage the wrench.

4.1.4. Clean compressor air inlet filter weekly.

4.1.5. Line pressure should be increased to compensate for unusually long air hoses (over 8 metres). The minimum hose diameter should be 1/2" internal diameter and fittings must have compatible inside dimensions.

4.1.6. Keep hose away from heat, oil and sharp edges. Check hose for wear and make certain that all connections are secure.

4.2. Couplings

Vibration may cause failure if a quick change coupling is connected directly to the wrench. To overcome this, connect a leader hose to the wrench (Sealey ref: AH2R or AH2R/38).

A quick change coupling may then be used to connect the leader hose to the air line recoil hose. See fig.1 & fig.2.

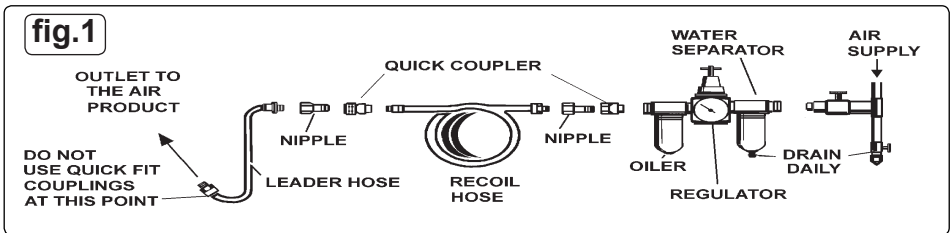

5. OPERATING INSTRUCTIONS

- ❑ **WARNING! Ensure you read, understand and apply safety instructions before use.**
- 5.1. Only use impact sockets which are specifically designed for use with an impact wrench.
- 5.2. Connect the wrench to the air hose as in Section 3.
- 5.3. Place the socket over the subject nut and depress the trigger to operate the wrench.
- 5.4. To change drive direction turn the direction control lever to the desired direction (fig.3).
DO NOT change direction whilst the wrench is running.
- 5.5. The speed may be adjusted in forward or reverse gear by adjusting the speed control (fig.3). There are two speed settings in both forward and reverse. **DO NOT** adjust speed or direction whilst the wrench is running.
DO NOT use any additional force upon the wrench in order to remove a nut. DO NOT allow wrench to free run for an extended period of time as this will shorten its life.
- ❑ **WARNING!** Disconnect wrench from air supply before changing accessories, servicing or performing maintenance. Replace or repair damaged parts. *Use genuine parts only. Unauthorised parts may be dangerous and will invalidate the warranty.*

6. MAINTENANCE

- 6.1. If the air system does not have an oiler, lubricate the air wrench daily with a few drops of Sealey air tool oil dripped into the air inlet.
- 6.2. Clean the wrench after use. **DO NOT use worn, or damaged sockets.**
- 6.3. Loss of power or erratic action may be due to the following:
 - 6.3.1. Excessive drain on the air line. Moisture or restriction in the air pipe. Incorrect size or type of hose connectors. To remedy, check the air supply and follow instructions in Section 4.
 - 6.3.2. Grit or gum deposits in the wrench may also reduce performance. Remove the strainer, clean it and flush the wrench out with gum solvent oil or an equal mixture of SAE No: 10 oil and paraffin. Allow to dry then lubricate before use.
- 6.4. For a full service, contact your local Sealey service agent.
- 6.5. When not in use, disconnect from air supply, clean wrench and store in a safe, childproof location.

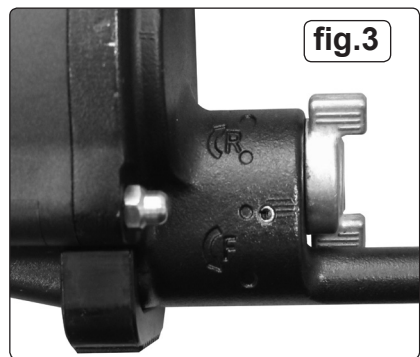
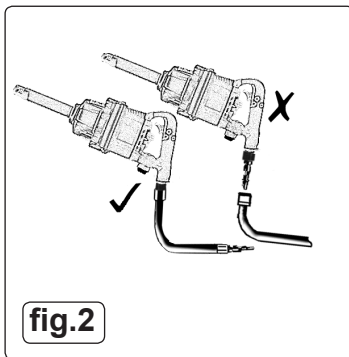

NOTE: It is our policy to continually improve products and as such we reserve the right to alter data, specifications and component parts without prior notice.

IMPORTANT: No liability is accepted for incorrect use of this product.

WARRANTY: Guarantee is 12 months from purchase date, proof of which will be required for any claim.

INFORMATION: For a copy of our latest catalogue and promotions call us on 01284 757525 and leave your full name and address, including postcode. 



Sole UK Distributor, Sealey Group,
Kempton Way, Suffolk Business Park,
Bury St. Edmunds, Suffolk,
IP32 7AR

 01284 757500

 www.sealey.co.uk

 01284 703534

 sales@sealey.co.uk

WARNING! – Risk of Hand Arm Vibration Injury.

This tool may cause Hand Arm Vibration Syndrome if its use is not adequately managed.

This tool is subject to the vibration testing section of the Machinery Directive 2006/42/EC.

This tool is to be operated in accordance with these instructions.

This tool has been tested in accordance with: EN ISO 28927- 2: 2009 & BS EN ISO 15744:2008.

Declaration and verification of Vibration Emission figures are in accordance with EN 12096: 1997

Measured vibration emission value (a): 5.5m/s²

Uncertainty value(k): 1.059m/s²

Please note that the application of the tool to a sole specialist task may produce a different average vibration emission. We recommend that a specific evaluation of the vibration emission is conducted prior to commencing with a specialist task.

A health and safety assessment by the user (or employer) will need to be carried out to determine the suitable duration of use for each tool.

NB: Stated Vibration Emission values are type-test values and are intended to be typical.

Whilst in use, the actual value will vary considerably from and depend on many factors.

Such factors include; the operator, the task and the inserted tool or consumable.

NB: ensure that the length of leader hoses is sufficient to allow unrestricted use, as this also helps to reduce vibration.

The state of maintenance of the tool itself is also an important factor, a poorly maintained tool will also increase the risk of Hand Arm Vibration Syndrome.

CORRECT USE.

Vibration emission is closely linked to the operating pressure in the air supply. The user should ensure that the pressure is set in accordance with our recommendations to assure optimum efficiency and minimise vibration exposure.

- Keep hands away from sockets when in use.
- Do not use ill-fitting or worn Sockets and Extensions as this will increase vibration.
- Ensure that the tool is correctly aligned to the work. Misalignment increases the risk of vibration injury.
- Ensure that consumables are selected, maintained and replaced in accordance with Sealey Instructions.
- Sleeve fittings must be used where possible.
- Always support the tool in a stand or on a balancer or a tension device where possible.
- Ensure that the operator is sufficiently experienced in order to be able to handle and operate the tool correctly.
- Ensure that the tool is held with a light but secure grip. Avoid excessive grip force as this will increase the risk of vibration injury.

MAINTENANCE.

If the air system does not have an oiler, lubricate the air tool daily with a few drops of Sealey air tool oil dripped into the air inlet. Clean the tool after use.

Loss of power or erratic action may be due to the following:

Excessive drain on the air line. Moisture or restriction in the air pipe. Incorrect size or type of hose connectors.

To remedy, check the air supply and follow instructions in the PREPARING FOR USE section..

Grit, residual deposits (gum) in the tool may also reduce performance.

Remove the strainer. Clean the strainer and flush the tool out with gum solvent oil or an equal mixture of SAE No:10 oil and paraffin. Allow the tool and strainer to dry then lubricate before use.

For a full service, contact your local Sealey service agent.

When not in use, disconnect the tool from the air supply, clean the tool and store the tool in a safe, childproof, location.

To reduce friction and increase the power and longevity of the tool; regularly lubricate the drive shaft and check and top up the gearbox (if fitted).

Health surveillance.

We recommend a programme of health surveillance to detect early symptoms of vibration injury so that management procedures can be modified accordingly.

Personal protective equipment.

We are not aware of any personal protective equipment (PPE) that provides protection against vibration injury that may result from the uncontrolled use of this tool. We recommend a sufficient supply of clothing (including gloves) to enable the operator to remain warm and dry and maintain good blood circulation in fingers etc. Please note that the most effective protection is prevention, please refer to the Correct Use and Maintenance section in these instructions. Guidance relating to the management of hand arm vibration can be found on the HSC website www.hse.gov.uk - Hand-Arm Vibration at Work.