



INSTRUCTIONS FOR: COMPRESSOR - 500LTR BELT DRIVE 10hp 2-STAGE WITH CAST CYLINDERS

MODEL No: **SAC65010B**

Thank you for purchasing a Sealey product. Manufactured to a high standard this product will, if used according to these instructions and properly maintained, give you years of trouble free performance.

IMPORTANT: PLEASE READ THESE INSTRUCTIONS CAREFULLY. NOTE THE SAFE OPERATIONAL REQUIREMENTS, WARNINGS & CAUTIONS. USE THE PRODUCT CORRECTLY AND WITH CARE FOR THE PURPOSE FOR WHICH IT IS INTENDED. FAILURE TO DO SO MAY CAUSE DAMAGE OR PERSONAL INJURY AND WILL INVALIDATE THE WARRANTY. PLEASE KEEP INSTRUCTIONS SAFE FOR FUTURE USE.



Guide to symbols

	Warning: Electricity		DO NOT open the air cock before an air hose is attached
	Warning: Hot Surface		DO NOT operate the compressor with enclosure displaced
	Warning: Automatic start up		Ensure oil level is correct before first use
	Wear ear protection		
	Read the instruction manual before use		

1. SAFETY

1.1. ELECTRICAL SAFETY

- WARNING!** It is the responsibility of the owner and the operator to read, understand and comply with the following: You must check all electrical products, before use, to ensure that they are safe. You must inspect power cables, plugs, sockets and any other connectors for wear or damage. You must ensure that the risk of electric shock is minimised by the installation of appropriate safety devices. A Residual Current Circuit Breaker (RCCB) should be incorporated in the main distribution board. We also recommend that a Residual Current Device (RCD) is used. It is particularly important to use an RCD with portable products that are plugged into a supply which is not protected by an RCCB. If in any doubt consult a qualified electrician. You may obtain a Residual Current Device by contacting your Sealey dealer. You must also read and understand the following instructions concerning electrical safety.
- 1.1.1. The **Electricity at Work Act 1989** requires that all portable electrical appliances, if used on business premises, are tested by a qualified electrician, using a Portable Appliance Tester (PAT), at least once a year.
- 1.1.2. The **Health & Safety at Work Act 1974** makes owners of electrical appliances responsible for the safe condition of those appliances and the safety of the appliance operators. **If in any doubt about electrical safety, contact a qualified electrician.**
- 1.1.3. Ensure that the insulation on all cables and on the appliance is safe before connecting it to the power supply. See 1.1.1. and 1.1.2. and use a Portable Appliance Tester.
- 1.1.4. Ensure that cables are always protected against short circuit and overload.
- 1.1.5. Regularly inspect power supply cables and plugs for wear or damage and check all connections to ensure that none is loose.
- 1.1.6. **Important:** Ensure that the voltage marked on the appliance matches the power supply to be used and that the plug is fitted with the correct fuse (see 1.1.10. below).
- 1.1.7. **DO NOT** pull or carry the appliance by the power cable.
- 1.1.8. **DO NOT** pull the plug from the socket by the cable.
- 1.1.9. **DO NOT** use worn or damaged cables, plugs or connectors. Immediately have any faulty item repaired or replaced by a qualified electrician.
- WARNING! ELECTRICAL INSTALLATION TO A 3 PHASE 415VOLT SUPPLY MUST ONLY BE CARRIED OUT BY A QUALIFIED ELECTRICIAN.**

- 1.1.10 This product must be fitted with a 3 phase plug wired as illustration in (fig.1), wired to an appropriately fused supply. Connect GREEN/YELLOW wire to Earth 'E'
Connect BROWN wire to L1 Terminal.*
Connect BLACK wire to L2 Terminal.*
Connect the GREY wire to L3 Terminal.*

***NOTE:** The cable core colours found in the mains cable on this compressor are consistent with Amendment 2 to 7671:2001. When completed, check there are no bare wires, that all wires have been connected correctly and the cable restraint is tight

WARNING! IT IS ESSENTIAL TO OBSERVE PULLEY DIRECTION ON INITIAL START UP, SEE PULLEY GUARD. IF INCORRECT, STOP IMMEDIATELY AND CONSULT A QUALIFIED ELECTRICIAN TO INVERT 2 PHASES*.

- 1.1.11 **DO NOT** use this product with an extension cable.

IMPORTANT USER INFORMATION!

Over-current protection of the power circuit is required in accordance with 7.2 of EN 60204-1:2006. The supply disconnecting device to be in accordance with 5.3 of EN 60204-1:2006. Ask a qualified electrician about compliance.

1.2. GENERAL SAFETY

- ✓ Familiarise yourself with the application and limitations of the compressor.
- ✓ Ensure the compressor is in good order and condition before use. If in any doubt do not use the unit and contact an electrician/service agent.
- WARNING! Compressor must only be serviced by an authorised agent. DO NOT tamper with, or attempt to adjust, pressure switch or safety valve.**
- ✓ Before moving, or maintaining the compressor ensure it is unplugged from the mains supply and that the air tank pressure has been vented.
- ✓ Maintain the compressor in good condition and replace any damaged or worn parts. Use genuine parts only. *Unauthorised parts may be dangerous and will invalidate your warranty.*

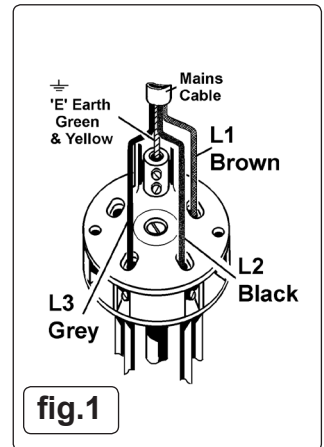

fig.1

- ✓ Read the instructions relating to any accessory to be used with this compressor. Ensure the safe working pressure of any air appliance used exceeds compressors output pressure. If using a spray gun, check that the area selected for spraying is provided with an air change system/ventilation.
- ✓ Ensure the air supply valve is turned off before disconnecting the air supply hose.
- ✓ Use the compressor in a well ventilated area and ensure it is placed on a firm surface.
- ✓ Keep tools and other items away from the compressor when it is in use, and keep area clean and clear of unnecessary items.
- ✓ Ensure the air hose is not tangled, twisted or pinched.
- ✓ Keep children and unauthorised persons away from the working area.
- X **DO NOT** dis-assemble compressor for any reason. The unit must be checked by qualified personnel only.
- X **DO NOT** use the compressor outdoors, or in damp, or wet, locations
- X **DO NOT** operate within the vicinity of flammable liquids, gases or solids.
- X **DO NOT** touch compressor cylinder, cylinder head or pipe from head to tank as these may be hot.
- X **DO NOT** use this product to perform a task for which it has not been designed.
- X **DO NOT** deface the certification plate attached to the compressor tank.
- X **DO NOT** cover the compressor or restrict air flow around the unit whilst operating.
- **DANGER! DO NOT** direct the output jet of air towards people or animals.
- X **DO NOT** operate the compressor without an air filter.
- X **DO NOT** allow anyone to operate the compressor unless they have received full instructions.
- **WARNING!** The air tank is a pressure vessel and the following safety measures apply:
- X **No welding operations are to be carried out on any pressurised parts of the vessel.**
- X **DO NOT** tamper with the safety valve, **DO NOT** modify or alter the tank in any way and **DO NOT** strap anything to the tank.
- X **DO NOT** subject the tank to impact, vibration or to heat and **DO NOT** allow contact with abrasives or corrosives.
- ✓ Drain condensation from tank and inspect inside walls for corrosion as per the maintenance schedule and have a detailed tank inspection carried out annually. The tank shell must not fall below the certified thickness at any point.
- **WARNING!** If an electrical fuse blows, ensure it is replaced with an identical fuse type and rating.
- ✓ When not in use for a prolonged period, and if possible, store the compressor carefully in a safe, dry, childproof location.

2. INTRODUCTION

Heavy duty three phase compressors suitable for the professional workshop. Two stage pump system coupled with a 10hp motor maximises performance to keep running costs low compared to single stage single phase models. A 500ltr tank allows for longer continuous air tool operation and less start ups hence using less power, saving on running costs. Pumps feature heavy duty full cast cylinders, capped by alloy heads for improved heat dissipation and long life. Heavy duty drive guards protect belt and flywheel, that is designed to force air over the pump to aid cooling. Supplied with full CE certification, test certificates and operating/maintenance manual.

3. SPECIFICATIONS

Model: **SAC65010B**
 Motor Output (HP): 10hp
 Voltage/Phase: 415-3hp
 Input current: 32A
 Speed (rpm): 1280
 Air Displacement (cfm/Lm): 38.4(1088)
 Max Free Air Delivery (cfm/Lm): 27.3(775)
 Max Pressure (psi/bar): 145/10
 Tank Capacity (L): 500
 Dimensions (WxDxH): 2000x700x1170mm
 Net Weight (kg): 255

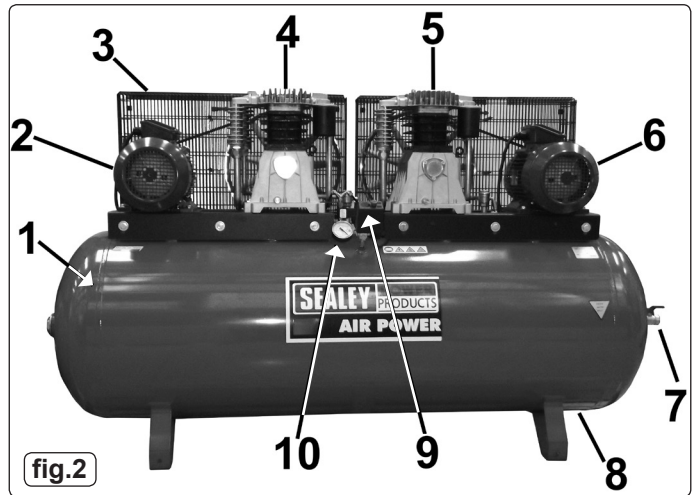

fig.2

1.	Tank	6.	Electric Motor 2
2.	Electric Motor 1	7.	Direct Air Outlet
3.	Belt Guard	8.	Condensate Drain
4.	Compressor Unit 1	9.	Pressure Switch
5.	Compressor Unit 2	10.	Pressure Gauge

4. OPERATION

4.1. Preparation

- 4.1.1. Remove compressor from the packaging.
- 4.1.2. Confirm that the mains voltage corresponds with the voltage shown on the compressor data plate. Fit a suitable 3 pin industrial plug - see section 1.1.10. of the Safety Instructions.
- 4.1.3. Take care to transport the compressor correctly, **DO NOT** overturn it or lift it with hooks or ropes.
- 4.1.4. Position the compressor on a flat, horizontal surface and ensure it is securely bolted down. Site in a well ventilated area, protected against atmospheric pollution and not in a place subject to explosion hazard.
- 4.1.5. To ensure good ventilation and efficient cooling, the compressor's belt guard must be at least 100cm from any wall (fig.3).
- 4.1.6. Remove the plastic transit plug from the oil filler hole, if fitted, (fig.4) and replace it with the dipstick. It is a push fit.
- 4.1.7. Before using the compressor, check the oil level on the dipstick in fig.4. If the oil is not up to the max. mark, it should be topped up with synthetic oil (see section 5.7. for recommended oils). We **DO NOT** recommend using mineral oil in these compressors. **DO NOT** overfill.

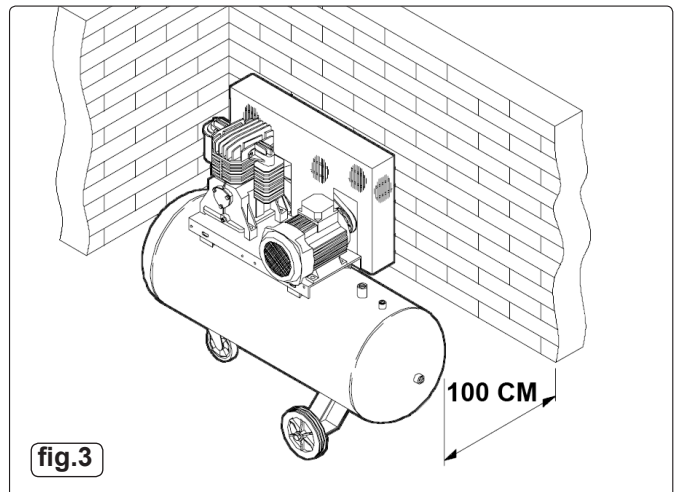
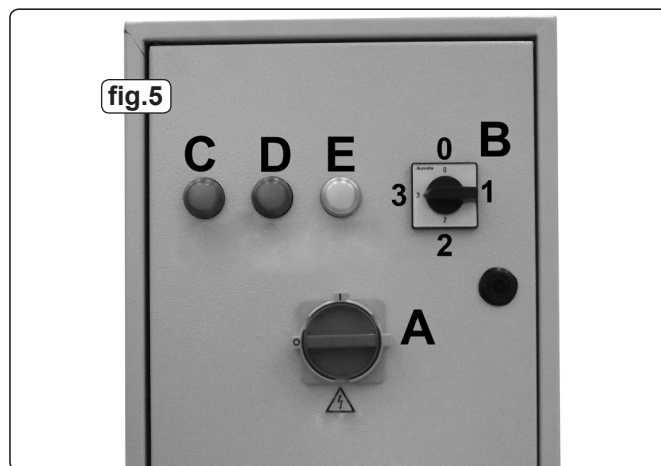
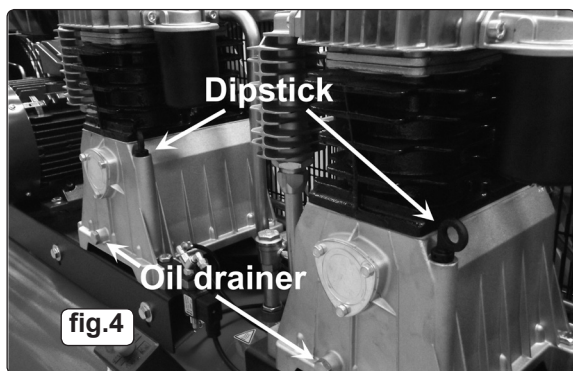
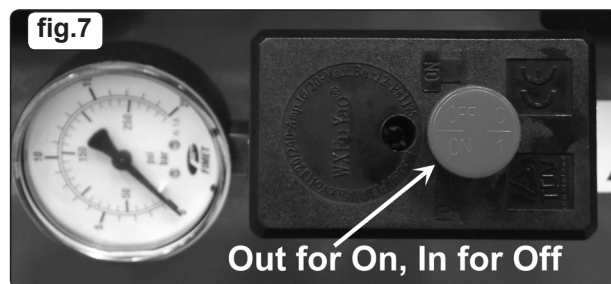
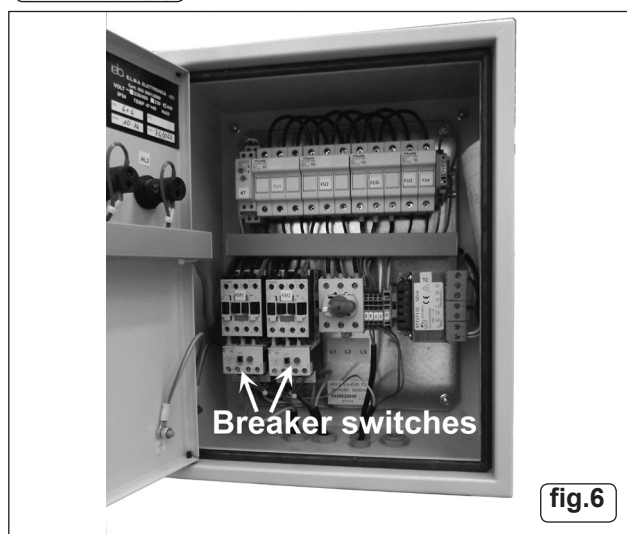

fig.3



**ISOLATE BEFORE OPENING
CONTROL CABINET**



On/Off switch sited on the tank (fig.2)

5. MAINTENANCE

In order to keep the compressor in good working condition, periodic maintenance is essential.

IMPORTANT! Failure to carry out maintenance tasks may invalidate the warranty on your compressor.

- ❑ **WARNING! Before performing any maintenance operation, switch off the compressor, disconnect from the electricity supply and release all air from the tank (except for 5.3.a)**
- 5.1. **Operations to be carried out after the first 50 working hours:**
 - a) Check that all bolts/nuts are tight, particularly those retaining the crankcase and cylinder head.
 - b) Replace the lubricating oil - see para 5.5.a. shown in fig.4.
- 5.2. **Operations to be carried out weekly:**
 - a) Drain condensation by opening the valve located under the tank (fig.7). Place a container under the valve and open the valve by turning anti-clockwise.
 - ❑ **WARNING! Take care if there is still pressure inside the cylinder as water could flow out with considerable force. Recommended pressure 1 - 2bar max.**
 - b) Check oil level and, if necessary, top up.

4.2. Operation

- ❑ **WARNING! Ensure that you have read, understood and apply Section 1 Safety Instructions.**
- ❑ **IMPORTANT! The use of extension leads is not recommended as the resulting voltage drop reduces motor, and therefore pump performance, and could cause damage to the compressor.**

NOTE: Take care when selecting tools for use with the compressor. Air tool manufacturers normally express the volume of air required to operate a tool in cubic feet per minute (cfm). This refers to free air delivered by the compressor ('air out') which varies according to the pressure setting. **DO NOT** confuse this with the compressor displacement which is the air taken in by the compressor ('air in'). 'Air out' is always less than 'air in' due to losses within the compressor.

STARTING THE COMPRESSOR Refer to fig.5

- 4.2.1. Connect the mains supply and pull the pressure switch up to its 'on' position, see fig.7.
- 4.2.2. Turn the master power switch 'A' on the control unit to the 'I' position - power On (signified by the white indicator light 'E' coming on.)
- 4.2.3. Turn switch 'B' to start the compressor, position 1 is compressor unit 1 operating only, position 2 is compressor unit 2 operating only, position 3 is both compressor units operating at the same time, at staggered starting times (timer in fig.6).
- 4.2.4. When starting the compressor for the first time, leave it running with no air tools connected to the air outlet. Make sure that the pressure in the tank rises and that the compressor stops automatically when the maximum pressure value allowed, written on the plate and shown on the gauge (fig.7) is achieved. The compressor will now operate automatically. The pressure switch stops the motor when the maximum tank pressure is reached and restarts it when the pressure falls below the minimum.
- 4.2.5. To stop the compressor, first turn the main switch "A" (fig.5) to the 'O' position and then turn the switch "B" (fig.5) to the '0' position. The compressed air inside the compressor heads will exhaust via check valves (fig.10), making the restart easier and preventing the motors from being damaged. **DO NOT**, other than in an emergency, stop the compressor by switching off at the mains, or by pulling the plug out, as the pressure relief will not then operate and motor damage may result upon restart.
- 4.2.6. The motors of the compressor are supplied with a manual reset thermal-overload, located on the terminal board cover, see fig.6. When the breaker is tripped, use the key to open the door, wait for a few minutes, and reset the overloads manually.
- 4.2.7. The safety device is automatic. When the thermal overload is tripped, wait for a few minutes to cool. The pressure switch is released to the 'O' Off position.

NOTE:

- a) If the motor does not cut in and out, but runs continuously when using an air appliance, the capacity of the compressor may be too small for the equipment or tool.
- b) The gauge (fig.7) indicates the pressure inside the main tank, **not** the pressure supplied to the air equipment. Should the pressure in the main tank exceed the pre-set switch maximum, the safety valve will activate.

WARNING! For this reason DO NOT tamper with, or adjust, the switch or safety valve.

5.3. Operations to be carried out every 50 hours

(or more frequently, if the compressor operates in a dusty atmosphere):

- a) Remove the air filter element (fig.8). Using stored air from the compressor's tank, clean the filter with compressed air. (Wear eye protection and **DO NOT** direct air towards the body or hands). **DO NOT** operate the compressor without the filter as foreign bodies or dust could seriously damage the pump. Replace the filter element and air filter housing.
- b) Check for oil leaks.

5.4. Operations to be carried out every 100 hours:

- a) Check the automatic cut-out at max. pressure and the automatic cut-in at 2bar below.

5.5. Operations to be carried out every 400 hours:

- a) Replace the lubricating oil. For oil specifications see 5.7. Remove the dipstick, then remove the oil drainer plug (fig.4), draining the oil into a container. Drain when the compressor is hot so that the oil drains rapidly and completely. Replace oil drain plug and refill through the dipstick. **DO NOT** overfill. Replace dipstick.

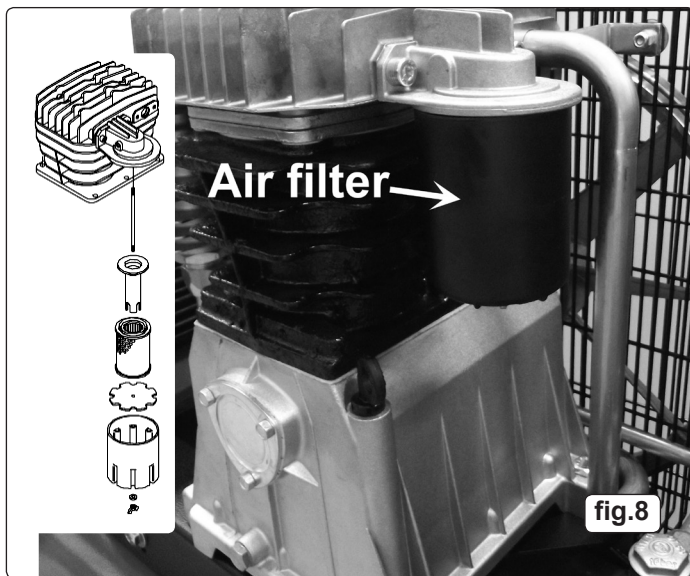

- ❑ **WARNING! Never mix different oils and DO NOT use non-detergent/low quality oils as the compressor may be damaged.**
- ❑ **WARNING! Dispose of waste oil only in accordance with local authority requirements.**
 - b) Replace air filter. (See fig.8)
 - c) Check all tube fittings and electrical connections.
 - d) Inspect pressure tank inside and out for damage or corrosion.

5.6. Maintenance Schedule

Maintenance Operations	Weekly	50hrs	100hrs	400 hrs
Drain condensation	●			
Check oil level	●			
Clean intake filter		●		
Check for oil leaks		●		
Replace oil				●
Check cut-out			●	
General cleaning of compressor			●	
Replace air filter				●
Check tube fittings and electrical connections				●

Inspection of pressure tank both inside and out.

Under the PRESSURE SYSTEMS SAFETY REGULATIONS 2000 it is the responsibility of the owner of the compressor to initiate a system of inspection that both defines the frequency of the inspection and appoints a person who has specific responsibility for carrying out the inspection.

5.7. Recommended oils

Synthetic oil suitable for temperatures ranging from -5°C to 45°C: viscosity 5W50. We do not recommend using mineral oil in these compressors.

Part No.	Qty.	Description
FSO1	1ltr x 12	Compressor oil fully synthetic
FSO1S	1ltr x 1	Compressor oil fully synthetic
FSO5	5ltr x 1	Compressor oil fully synthetic

- 5.8. IMPORTANT WARNING** - Air contaminants taken into the compressor will affect optimum performance. Example: Body filler dust or paint overspray will clog the pump intake filter and may cause internal damage to pump/motor components. Please note that any parts damaged by any type of contamination will not be covered by warranty.

6. TROUBLESHOOTING

Fault	Cause	Remedy
Pressure drop in the tank.	Air leaks at connections.	Run compressor to max. pressure, switch off. Brush soap solution over connections and look for bubbles. Tighten connections showing leaks. If problem persists contact Authorised Service Agent.
Pressure switch valve leaks when compressor is idle.	Non-return valve seal defective.	Discharge all tank pressure. Referring to fig.10, unscrew valve cap 'A'. Clean rubber disc 'B' and its seat. Refit all parts accurately.
Compressor stops and does not restart.	Power failure. Motor failure.	Check electricity supply and fuse. Contact Authorised Service Agent.
Compressor does not stop at max pressure.	Pressure switch fault.	Contact Authorised Service Agent.
Compressor does not reach max pressure.	Filter clogged. Head gasket or valve fault.	Replace filter element. Contact Authorised Service Agent.
Compressor noisy with metallic knock.	Low oil level. Bearing or piston damage.	Turn off and top up oil immediately. Contact Authorised Service Agent.

fig.9



fig.10

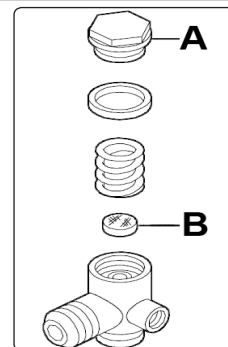

**Environmental Protection.**

Recycle unwanted materials instead of disposing of them as waste. All tools, accessories and packaging should be sorted, taken to a recycle centre and disposed of in a manner which is compatible with the environment.

**WEEE Regulations.**

Dispose of this product at the end of its working life in compliance with the EU Directive on Waste Electrical and Electronic Equipment. When the product is no longer required, it must be disposed of in an environmentally protective way. Contact your local solid waste authority for recycling information.

Parts support is available for this product. To obtain a parts listing and/or diagram, please log on to www.sealey.co.uk, email sales@sealey.co.uk or telephone 01284 757500.

NOTE: It is our policy to continually improve products and as such we reserve the right to alter data, specifications and component parts without prior notice.

IMPORTANT: No liability is accepted for incorrect use of this product.

WARRANTY: Guarantee is 12 months from purchase date, proof of which will be required for any claim.



Sole UK Distributor, Sealey Group,
Kempson Way, Suffolk Business
Park, Bury St. Edmunds, Suffolk,
IP32 7AR



01284 757500



01284 703534



www.sealey.co.uk



sales@sealey.co.uk

