

Thank you for purchasing a Sealey product. Manufactured to a high standard this product will, if used according to these instructions and properly maintained, give you years of trouble free performance.

⚠ IMPORTANT: PLEASE READ THESE INSTRUCTIONS CAREFULLY. NOTE THE SAFE OPERATIONAL REQUIREMENTS, WARNINGS & CAUTIONS. USE THE PRODUCT CORRECTLY AND WITH CARE FOR THE PURPOSE FOR WHICH IT IS INTENDED. FAILURE TO DO SO MAY CAUSE DAMAGE OR PERSONAL INJURY, AND WILL INVALIDATE THE WARRANTY. PLEASE KEEP INSTRUCTIONS SAFE FOR FUTURE USE.

1. SAFETY INSTRUCTIONS

1.1 GENERAL SAFETY

- ❑ **WARNING!** Ensure Health & Safety, and local authority regulations are adhered to when assembling and using this racking system.
- ✓ Locate the racking in a suitable area where it will not be an obstruction.
- ✓ Keep the general area clean, uncluttered and ensure there is adequate lighting.
- ❑ **WARNING!** Use the racking on a level and solid surface such as concrete.
- ✓ Keep children and unauthorised persons away from the storage area.
- x **DO NOT** use the racking for any purpose other than that for which they are designed.
- x **DO NOT** get the racking wet or use in damp or wet locations or areas where there is condensation.
- x **DO NOT** clean the cross beams with any solvents which may damage the coated surface.
- x **DO NOT** overload the racking.
- x **DO NOT** allow others to ride on the racking.
- x **DO NOT** push loaded racking over edges, rough surfaces etc. as the whole unit may overturn.
- ✓ Ensure that the racking is properly assembled before loading with heavy tyres.
- ❑ Maximum load for each level is 200kg. Load must be evenly distributed.
- ✓ Place heavier items on the lower racks.
- ✓ Maintain correct balance and footing when moving the racking and ensure that the floor surface is not slippery.
- ✓ Where possible heavier items should be evenly distributed across the racks.

2. INTRODUCTION

Three level mobile tyre rack system helps keep working area clear. Unit is on wheels for easy manoeuvrability when needing to take the tyres to point of work, ideal for use track side. Steel construction with a powder coated finish giving anti-corrosion resistance.

Height: 1700mm Width: 915mm Depth: 455mm
Maximum Capacity: 600kg (200kg/Level)

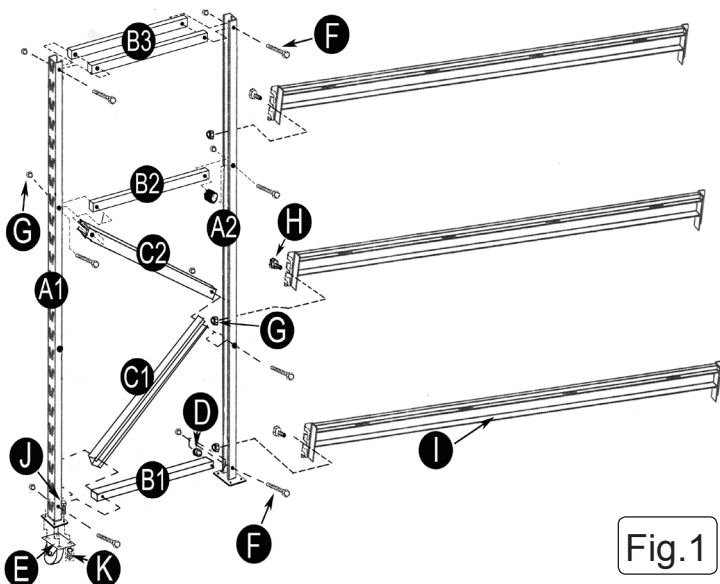

Fig.1

3. CONTENTS

Carefully unpack the product and check the contents (fig.1) against the list below. Should any items be missing or damaged, immediately contact your Sealey dealer.

| Part Description..... | Quantity |
|----------------------------------|----------|
| A Upright..... | 4 |
| B Horizontal Brace..... | 8 |
| C Diagonal Brace..... | 4 |
| D Spacer..... | 4 |
| E Castor*..... | 4 |
| F Bolt M6 x 50mm..... | 14 |
| G Nut M6..... | 26 |
| H Safety Bolt M6 x 20mm..... | 12 |
| I Cross Beam..... | 6 |
| J Bolt M10 x 20mm..... | 16 |
| K Nut M10 and Spring Washer..... | 16 |

* 2 x Swivel Castors and 2 x Fixed Castors

4. ASSEMBLY

- ❑ **Warning!** Before assembly and use ensure you have read, understood and apply Section 1 safety instructions.

4.1 It is recommended that this tyre racking system be assembled by two people. When installing the cross beams it is advisable to use a rubber mallet. Do not use a hard faced hammer as this will damage the surface finish of the cross beams. Make sure that all the clips lock in place securely and safety bolts are fitted before using the unit. Do not use any parts that are damaged and/or distorted as these may assemble incorrectly and result in an installation that is unsafe and which may cause injury or damage when the shelves are loaded.



4.2 Assembling the end frames. Refer to Fig.1.

- 4.2.1 Attach a castor (E) into one end of each of the uprights (A1 & A2) using bolts M10 x 20mm (J) and M10 nuts and spring washers (K).

Note: Ensure that the castors are attached in pairs for each assembled frame, i.e. fixed castors on one frame and swivel castors on the other.

- 4.2.2 Place the uprights (A1 & A2) on the floor with the inner edges facing each other and the castors at the base.
- 4.2.3 Take one horizontal brace (B1) and one spacer (D). Insert into the upright (A2) at the base area drilled hole and loosely secure using a M6 x 50mm bolt (F) and a M6 nut (G).
- 4.2.4 Place the other upright (A1) so that the horizontal brace (B1) aligns with the base area drilled hole. Take one of the diagonal braces (C1) and insert into the upright (A1) so that the hole aligns with the hole in the horizontal brace (B1) and the drilled hole in the upright (A1). Loosely secure using a M6 x 50mm bolt (F) and a M6 nut (G).
- 4.2.5 Align the other end of the diagonal brace (C1) with the corresponding hole in the opposite upright (A2). Take another diagonal brace (C2) and align with the same hole on diagonal brace (C1) and on the upright (A2). Loosely secure using a M6 x 50mm bolt (F) and a M6 nut (G).
- 4.2.6 Align the other end of the second diagonal brace (C2) with the corresponding hole in the opposite upright (A1). Take a second horizontal brace (B2) and align with the second diagonal brace (C2). Loosely secure using a M6 x 50mm bolt (F) and a M6 nut (G).
- 4.2.7 Align the remaining end of horizontal brace (B2) with the hole of the opposite upright (A2), insert a spacer (D) in the gap and loosely secure using a M6 x 50mm bolt (F) and a M6 nut (G). Place the last two horizontal braces (B3) together across the top of the uprights (A1 & A2). Loosely secure using M6 x 50mm bolts (F) and a M6 nuts (G).
- 4.2.8 Check that the assembled frame is square and tighten all the fasteners. Repeat the procedure for the second frame assembly.

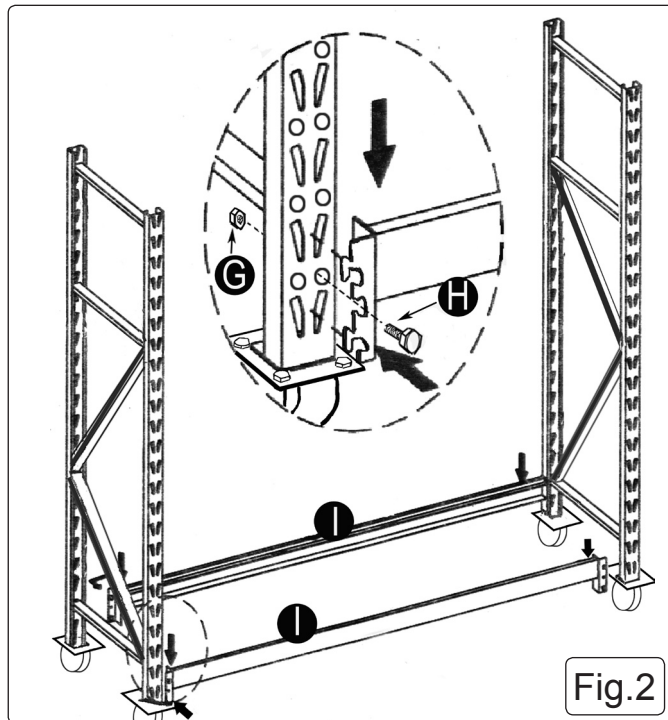

Fig.2

4.3 Fitting the cross beams. Refer to Fig.2.

- 4.3.1 Support one end frame in a vertical position and attach the end of one cross beam (I) to it at the base of one of the uprights (A). Ensure that both tags on the end bracket engage properly with the slots in the upright as shown in the inset diagram. Tap the cross beam gently next to the end bracket so that the beam is properly seated into the slots in the upright. Insert the safety bolt (H) so that it is against the beam and secure with a M6 nut (G). Connect the other end of the beam to the second end frame at the same height, tap into place and secure with a safety bolt (H) and M6 nut (G).
- 4.3.2 Attach another cross beam (I) to the other side of the end frames ensuring that it is at the same level as the first cross beam.
- 4.3.3 See Fig.3. Continue to assemble the next two pairs of cross beams (I) at the heights required. The end frames allow adjustment in 2" increments. Each pair of beams must be mounted at the same height. Ensure that all tabs on the cross beam brackets are fully engaged in the slots in the uprights and that the cross beams are properly tapped down into place then secured with a safety bolt (H) and a M6 nut (G).

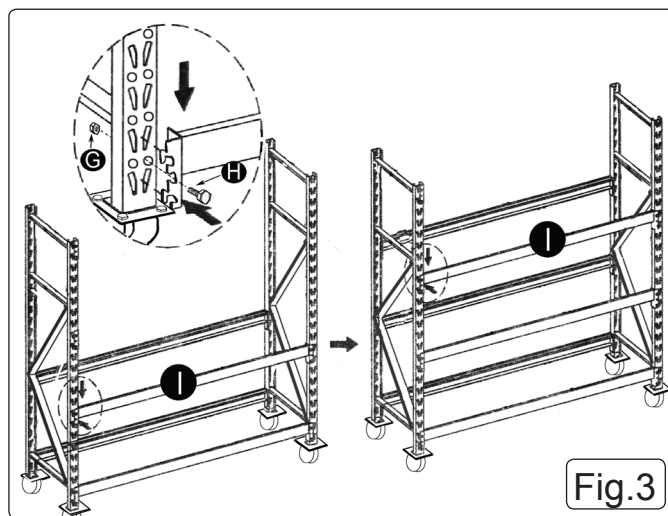

Fig.3

Parts support is available for this product.

To obtain a parts list and diagram please log on to www.sealey.co.uk, email sales@sealey.co.uk or phone 01284 757500

NOTE: It is our policy to continually improve products and as such we reserve the right to alter data, specifications and component parts without prior notice.

IMPORTANT: No liability is accepted for incorrect use of this product.

WARRANTY: Guarantee is 12 months from purchase date, proof of which will be required for any claim.

INFORMATION: For a copy of our latest catalogue and promotions call us on 01284 757525 and leave your full name and address, including postcode.



Sole UK Distributor, Sealey Group,
Kempson Way, Suffolk Business Park,
Bury St. Edmunds, Suffolk,
IP32 7AR

01284 757500

01284 703534

www.sealey.co.uk

sales@sealey.co.uk