

Thank you for purchasing a Sealey product. Manufactured to a high standard this product will, if used according to these instructions and properly maintained, give you years of trouble free performance.



IMPORTANT: PLEASE READ THESE INSTRUCTIONS CAREFULLY. NOTE THE SAFE OPERATIONAL REQUIREMENTS, WARNINGS & CAUTIONS. USE THE PRODUCT CORRECTLY AND WITH CARE FOR THE PURPOSE FOR WHICH IT IS INTENDED. FAILURE TO DO SO MAY CAUSE DAMAGE AND/OR PERSONAL INJURY AND WILL INVALIDATE THE WARRANTY. PLEASE KEEP INSTRUCTIONS SAFE FOR FUTURE USE.

1. SAFETY INSTRUCTIONS

1.1. GENERAL SAFETY INSTRUCTIONS

- ✓ Ensure the bead seating tool is in good order and condition before use.
- ✓ Before carrying out maintenance on the unit ensure that the pressure has been vented.
- ✓ Use only authorised attachments and parts. Unauthorised items may be dangerous and will invalidate your warranty.
- ✓ Read the instructions regarding any accessory used with the bead seater.
- ✓ Keep the work area clean and tidy.
- ✓ Ensure the working area is well lit.
- ✓ Always wear safety glasses and ear defenders when using the bead seater.
- ✓ Keep children and unauthorised persons away from the working area.
- X **DO NOT** use the bead seater to perform a task for which it is not designed.
- X **DO NOT** deface, or remove, the certification plate attached to the bead seater.
- ▲ **DANGER! DO NOT** direct compressed air towards people or animals.
- **WARNING! The bead seater is a pressure vessel and the following safety measures apply:**
 - DO NOT** use the bead seater without the safety valve fitted.
 - DO NOT** tamper with the safety valve, **DO NOT** modify or alter the bead seater in any way and **DO NOT** strap anything to it.
 - DO NOT** subject the bead seater to impact, vibration or heat and **DO NOT** allow contact with abrasives or corrosives.
 - Drain condensation from bead seater daily, inspect inside walls for corrosion every three months and have a detailed inspection carried out annually. The bead seater shell must not fall below the certified thickness at any point.

WARNING! The warnings, cautions and instructions discussed in this manual cannot cover all possible conditions and situations that may occur. It must be understood that common sense and caution are factors which cannot be built into this product, but must be applied by the operator.

2. INTRODUCTION & SPECIFICATION

The easy and instant way to seat tubeless tyre beads. Dumps air into tyre void forcing bead to seat against rim for inflation. Fully certified tank with gauge and safety valve prevents over pressurising. Suitable for use on cars, commercials, agricultural and ATV tyres.

Specification

Weight 11.2kg
Capacity 20ltr
Max. Pressure 145psi / 10bar

3. CONTENT & ASSEMBLY

- 3.1 Screw the locking ring onto the barrel and screw into the release valve (Fig.2.C) as shown in Fig.1.
- 3.2 Fit the air line connection (not supplied) (Fig.2.B) into the inlet valve (Fig.2.A).

4. OPERATION

4.1 To Charge the tank.

- 4.1.1. Ensure that the release valve (C) is in the closed position as shown in Fig.2.
- 4.1.2. Attach an air line to the air inlet connection on the bead seater, open the inlet valve (A) and charge the tank to the required pressure. The normal working pressure varies from 50psi to 130psi, depending on the size and condition of the tyre. The bead seater can help inflate all passenger, truck and even some small agricultural tyres. When used in the wheel in the upright position it will normally require a pressure over 90psi to set the bead.

4.2 Using the Bead Seater in the horizontal position.

- 4.2.1. Adjust the barrel, so that the barrel flange is on the top, ensuring that the lock nut is secure.
- 4.2.2. Ensure that both beads of the tyre have been well lubricated and position the wheel on to a stand, the valve stem should be pointing upwards and the wheel should be off the ground so that the lower bead should be already seated.

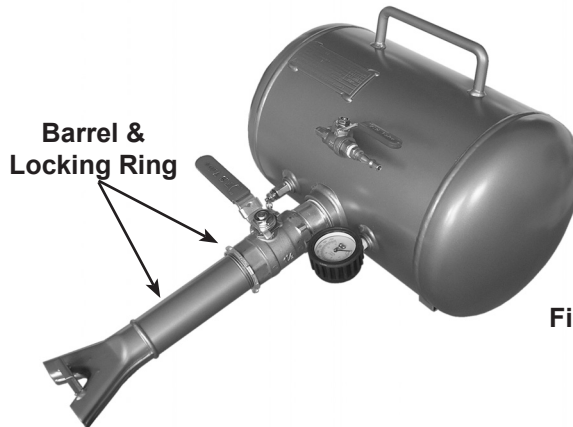

Fig.1

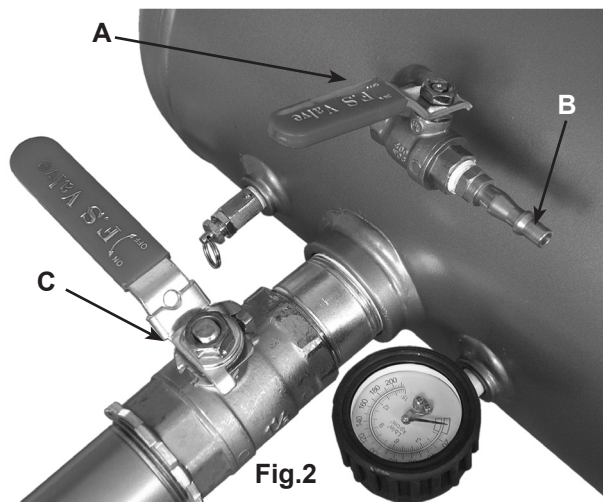

Fig.2

4.2.3. Position the bead seater so that the weight of the unit is resting on your leg, rest the barrel flange on the rim of the wheel directly opposite the valve stem. Attach an air line to the valve stem to simultaneously assist in the inflation process. The bead seater should be positioned at an angle of between 50 and 70 degrees (Fig.4a), so that the barrel is pointing directly into the largest gap between the tyre and the wheel (Fig.4b).

4.2.4. Holding the bead seater securely with one hand and keeping it steady against the wheel, lift up the safety catch (Fig.3) and quickly open the release valve with the other hand, if the bead does not seat, recharge the tank to a higher pressure and repeat the procedure.

NOTE: Once the bead has been set, if required, move the wheel into a tyre cage and inflate to the manufacturers recommended pressure.

4.3 Using the Bead Seater in the upright position (truck tyres only).

4.3.1 Adjust the barrel, so that the barrel flange is on the bottom, ensuring that the lock nut is secure.

4.3.2 Position the wheel against a wall or a solid prop. Make sure that the valve stem is at the bottom and facing towards you.

4.3.3 Attach an air line to the valve stem to simultaneously assist in the inflation process.

4.3.4 The bead seater should be positioned at an angle of between 50 and 70 degrees (Fig.5b), so that the barrel is pointing directly into the largest gap between the tyre and the wheel (Fig.5a).

4.3.5 Holding the bead seater securely with one hand and keeping it steady against the wheel, lift up the safety catch (Fig.3) and quickly open the release valve with the other hand, if the bead does not seat, recharge the tank to a higher pressure and repeat the procedure.

NOTE: Once the bead has been set, if required, move the wheel into a tyre cage and inflate to the manufacturers recommended pressure.

WARNING! Always wear the personal safety equipment as stated in section 1.1 whilst using this product.

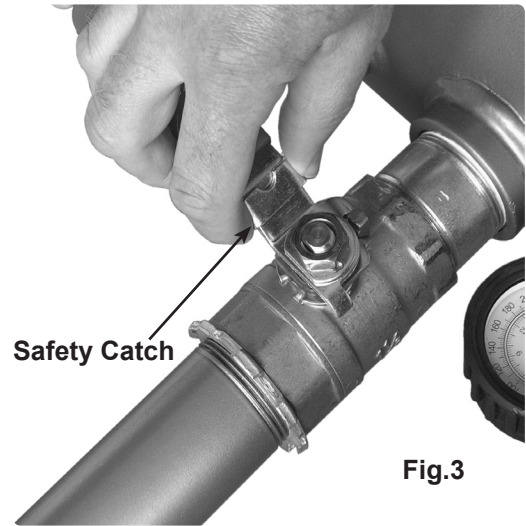
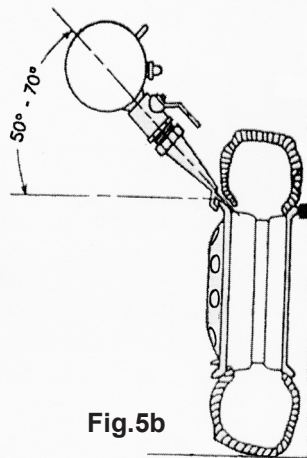
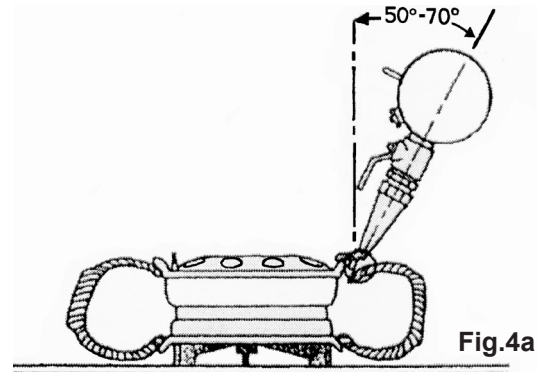

Fig.3



NOTE: It is our policy to continually improve products and as such we reserve the right to alter data, specifications and component parts without prior notice.

IMPORTANT: No liability is accepted for incorrect use of this product.

WARRANTY: Guarantee is 12 months from purchase date, proof of which will be required for any claim.

INFORMATION: For a copy of our latest catalogue and promotions call us on 01284 757525 and leave your full name and address, including postcode.



Sole UK Distributor, Sealey Group,
Kempson Way, Suffolk Business Park,
Bury St. Edmunds, Suffolk,
IP32 7AR

☎ 01284 757500

📠 01284 703534

🌐 www.sealey.co.uk

✉ sales@sealey.co.uk