



INSTRUCTIONS FOR MANUAL TYRE CHANGER MODEL NO: **TC960.V2**

Thank you for purchasing a Sealey product. Manufactured to a high standard, this product will, if used according to these instructions, and properly maintained, give you years of trouble free performance.

IMPORTANT: PLEASE READ THESE INSTRUCTIONS CAREFULLY. NOTE THE SAFE OPERATIONAL REQUIREMENTS, WARNINGS & CAUTIONS. USE THE PRODUCT CORRECTLY AND WITH CARE FOR THE PURPOSE FOR WHICH IT IS INTENDED. FAILURE TO DO SO MAY CAUSE DAMAGE AND/OR PERSONAL INJURY AND WILL INVALIDATE THE WARRANTY. KEEP THESE INSTRUCTIONS SAFE FOR FUTURE USE.



Refer to instruction manual



Wear eye protection



Wear safety footwear



Wear protective gloves

1. SAFETY

- WARNING!** Ensure Health & Safety, local authority and general workshop practice regulations are adhered to when using this equipment.
- Familiarise yourself with the applications, limitations and the potential hazards of the tyre changer.
- Maintain the tyre changer in good condition (use an authorised service agent).
- Replace or repair damaged parts. *Use genuine parts only. Unauthorised parts may be dangerous and will invalidate the warranty.*
- WARNING!** Check regularly for damaged parts. Any part that is damaged must be repaired or replaced before the equipment is next used.
- Locate the tyre changer in a suitable work area and keep area clean and tidy and free from unrelated materials. Ensure that there is adequate lighting.
- WARNING!** Use on a level surface, preferably concrete, **to which the tyre changer must be bolted.**
- Keep the tyre changer clean for best and safest performance.
- Wear approved safety eye protection (standard spectacles are not adequate).
- Keep hands and feet well clear of the bead breaker.
- Maintain correct balance and footing. Ensure the floor is not slippery and wear non-slip shoes.
- Remove ill fitting clothing. Remove ties, watches, rings and other loose jewellery and contain and/or tie back long hair.
- Keep children and unauthorised persons away from the work area.
- DO NOT** use the tyre changer for any purpose other than that for which it is designed.
- DO NOT** operate the tyre changer if any parts are damaged or missing as this may cause failure and/or personal injury.
- DO NOT** allow untrained persons to operate the tyre changer.
- DO NOT** stand on the tyre changer.
- DO NOT** operate the tyre changer when you are tired or under the influence of alcohol, drugs or intoxicating medication.

2. INTRODUCTION

Steel construction with manual bead breaker. Suitable for use on most open centred wheels. Supplied with tyre bar. To prevent damage to the rims of an alloy wheel, it is essential to use a TC963 Tyre Bar.

3. SPECIFICATION

Model no:	TC960.V2
Min. Wheel Diameter	n/a
Max. Wheel Diameter	n/a
Min. Wheel Depth	0mm
Max. Wheel Depth	300mm
Working Height	640mm
Centre Post Sizes	41mm

4. ASSEMBLY

Numbers/letters in brackets refer to those shown in the parts diagram.

- 4.1. Attach the pedestal (3) to the base (1) using the bolts (11), washers (14) and nuts (12) provided. Note that the longer end of the base should be below the bead breaker (7).
- 4.2. Attach the two side base channels (2) to the pedestal using bolts, washers and nuts, as above.
Note: There are two holes in the base and one in each side base for securely mounting the tyre changer to the floor.

5. OPERATION

- 5.1. The **TC960** Tyre Changer is manually operated - no air supply is required. It is designed for removing/fitting tyres from/to most sizes of open-centre wheels (see Section 3 Specification). **DO NOT** use the tyre changer for any other purpose.
- 5.2. If tyres are to be changed on aluminium wheels the optional tyre bar, Sealey model no. **TC963**, must be used to prevent damage to the wheel rims.
▲ IMPORTANT! Never attempt to fit or remove a tyre without first lubricating both beads (lubricant not supplied).
- 5.3. **Bead breaking - refer to fig. 1**
- 5.3.1. Deflate the tyre and remove all balance weights.

- 5.3.2. Lift the bead breaker (7) clear of the base (1).
- 5.3.3. Place the wheel flat on the base (1), locating the rim on the angled stop welded to the pedestal base. Position the bead breaker under the rim flange (fig. 1). Depending on the size of the tyre it may be necessary to adjust the height of the bead breaker (7). Remove hinge bolts (5), reposition bead breaker to suit the tyre and refit clevis pins. **DO NOT** forget to replace the locking nuts (6).
- 5.3.4. Put the tyre bar (10) into the bead breaker handle (4).
- 5.3.5. Pull down firmly on the bar and repeat around the rim until the bead is free.
- 5.3.6. Turn the wheel over and repeat to free the other bead.
- Note:** When bead breaking on TD or TDX wheels the wheel **must be horizontal**. Locate the rim on the base of the tyre changer and support the opposite side of the wheel with a suitable piece of timber.
- 5.4. **Tyre removal - refer to figs. 1, 2 and 3**
- 5.5. Lubricate both tyre beads with an approved rubber lubricant.
- 5.5.1. Remove the cap (9) and the wheel retaining spider (8) from the pedestal (3).
- 5.5.2. Place the wheel onto the tyre table (3) **with the valve stem uppermost** and locate the wheel peg rod through one of the wheel mounting holes.
- 5.5.3. Replace the spider (8) and the cap (9) onto the pedestal (3), see fig. 2, and hand tighten the cap.
- 5.5.4. Insert the flat end of the tyre bar (10) beneath the top bead and press the opposite side of the bead down into the wheel well.
- 5.5.5. Lever the bar against the cap (9) and rotate the bead over the rim (fig. 3).
- 5.5.6. If a tube is fitted, pull it out.
- 5.5.7. Pull the tyre up and repeat the procedure for the lower bead.
- 5.6. **Tyre fitting - refer to fig. 4**
- 5.7. Lubricate both tyre beads with an approved rubber lubricant.
- 5.7.1. Mount and lock the wheel to the stand as in 5.2.2. to 5.2.4.
- 5.7.2. Place the lower bead of the tyre over the wheel rim and insert the fitting head of the tyre bar (10) between the bead and the rim with the bead on the ledge of the fitting head.
- 5.7.3. Lever the bar against the cap (9) and rotate the bead over the rim (fig. 4).
- 5.7.4. Fit a tube if appropriate and then seat the upper bead in the same manner.

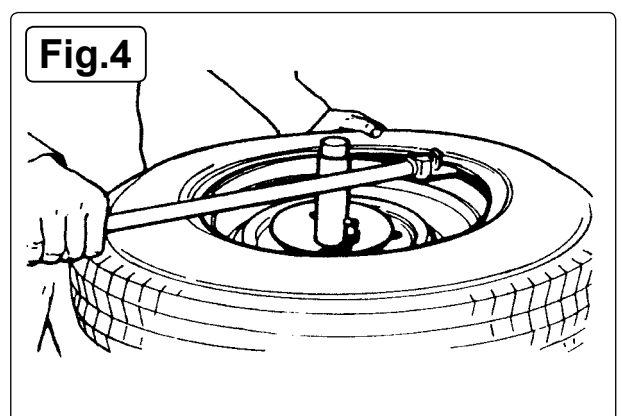
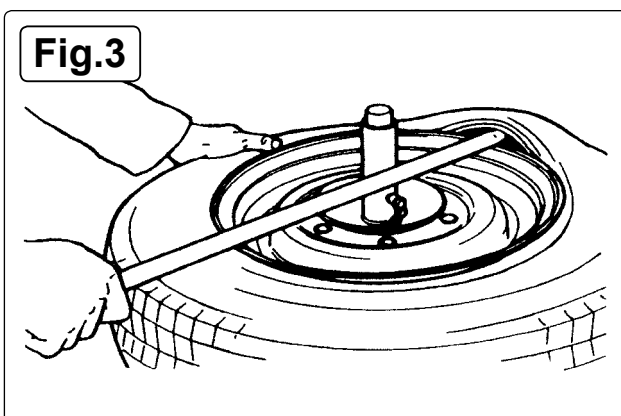
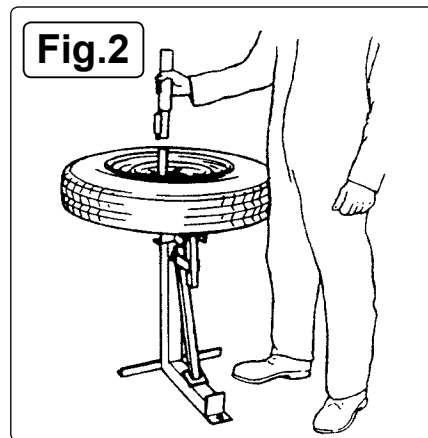
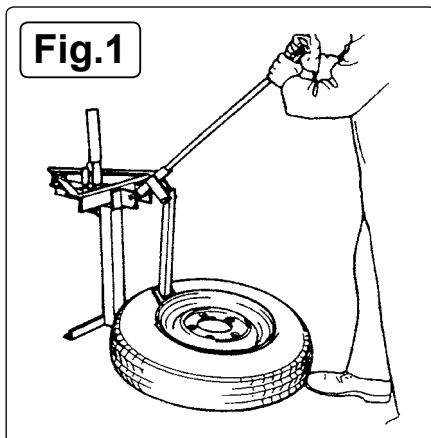

ENVIRONMENT PROTECTION

Recycle unwanted materials instead of disposing of them as waste. All tools, accessories and packaging should be sorted, taken to a recycling centre and disposed of in a manner which is compatible with the environment. When the product becomes completely unserviceable and requires disposal, drain any fluids (if applicable) into approved containers and dispose of the product and fluids according to local regulations.

Note: It is our policy to continually improve products and as such we reserve the right to alter data, specifications and component parts without prior notice.

Important: No Liability is accepted for incorrect use of this product.

Warranty: Guarantee is 12 months from purchase date, proof of which is required for any claim.

Sealey Group, Kempson Way, Suffolk Business Park, Bury St Edmunds, Suffolk. IP32 7AR



01284 757500



01284 703534



sales@sealey.co.uk



www.sealey.co.uk