

Thankyou for purchasing this Sealey product. Manufactured to a high standard this product will, if used according to these instructions and properly maintained, give you years of trouble free performance.



IMPORTANT: READ THESE INSTRUCTIONS CAREFULLY. USE THIS CLUTCH ALIGNMENT TOOL CORRECTLY AND WITH CARE FOR THE PURPOSE FOR WHICH IT IS INTENDED. FAILURE TO DO SO MAY CAUSE DAMAGE OR PERSONAL INJURY AND WILL INVALIDATE THE WARRANTY. RETAIN THESE INSTRUCTIONS FOR FUTURE USE.

1. SAFETY INSTRUCTIONS

- WARNING!** Ensure that Health and Safety, local authority and general workshop practice regulations are adhered to when using this tool.
- DO NOT** use this tool if damaged.
- Maintain tool in a good and clean condition for best and safest performance.
- Ensure that the ignition key is removed, to prevent inadvertent engine cranking.
- If the vehicle to be worked on is raised, ensure that it is adequately supported with axle stands or ramps and chocks.
- Wear suitable clothing to avoid snagging. **DO NOT** wear loose jewellery and tie back long hair.
- Account for all tools and parts being used.
- If working off the vehicle, ensure that the workpiece is secure and stable.
- DO NOT** use the alignment tool if you are tired or under the influence of alcohol, drugs or intoxicating medication.

IMPORTANT: Always refer to the individual vehicle manufacturer's service instructions, or a proprietary manual, to establish the correct procedure and data for the use of this tool.

This document is provided as a guide only.

2. SPECIFICATION

An essential tool designed to test the condition of a Dual Mass Flywheel (DMF). Use with the DMF fitted to the vehicle and with the gearbox/clutch removed. Fitting a new clutch with a faulty DMF may result in early failure of the new clutch. Results may be checked against the vehicle manufacturer's specification.

3. CONTENTS

Refer to picture below

Slotted Bar (1)

Slotted Bar Adapters x 6 (M6x1.0, M7x1.0, M8x1.25 two of each) (2)

Angular Torque Gauge (3)

DTI Gauge (shown without its box) (4)

DTI Gauge Bracket Including Mounting Plate (5) and Retaining Bolt (6)

Ring Gear Locking Tools x 2 (7)

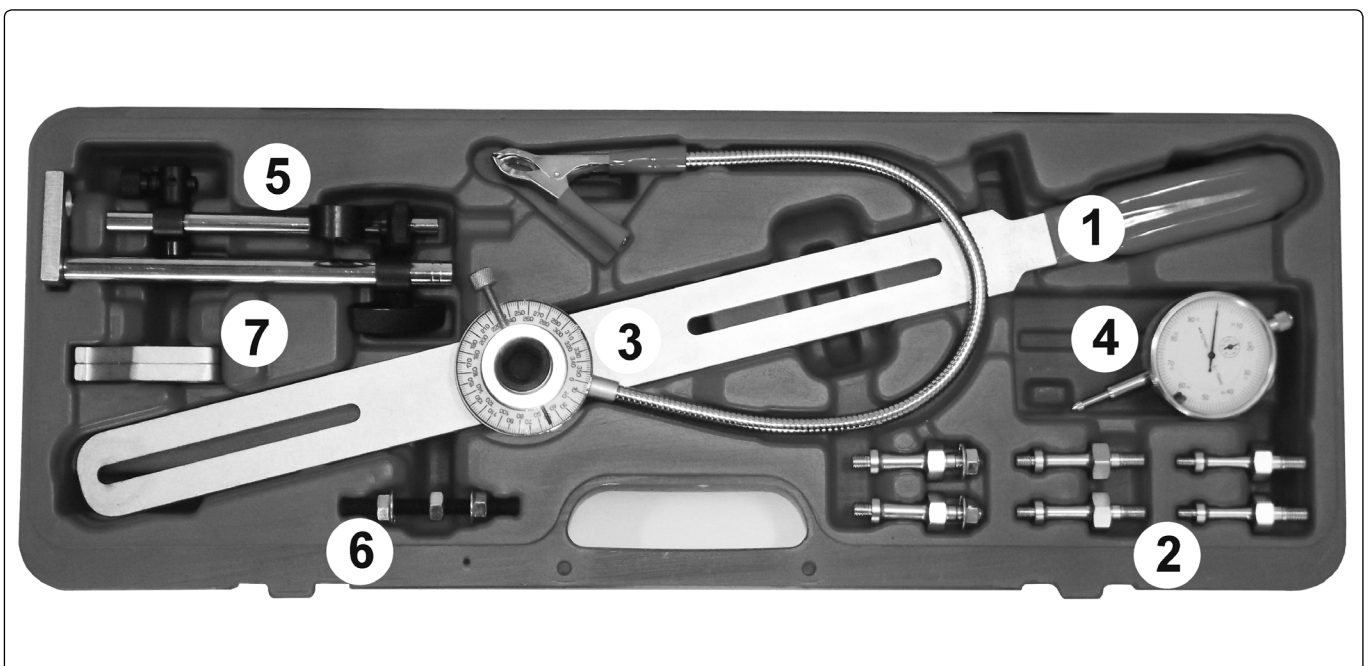

4. OPERATION

4.1 Remove gearbox from the vehicle as per the manufacturer's instructions.

Note: The dual mass flywheel is in two parts of which, one half is connected to the gearbox and thus will be removed when the gearbox is removed from the vehicle, and the other is connected to the crankshaft. Testing is carried out on the engine side.

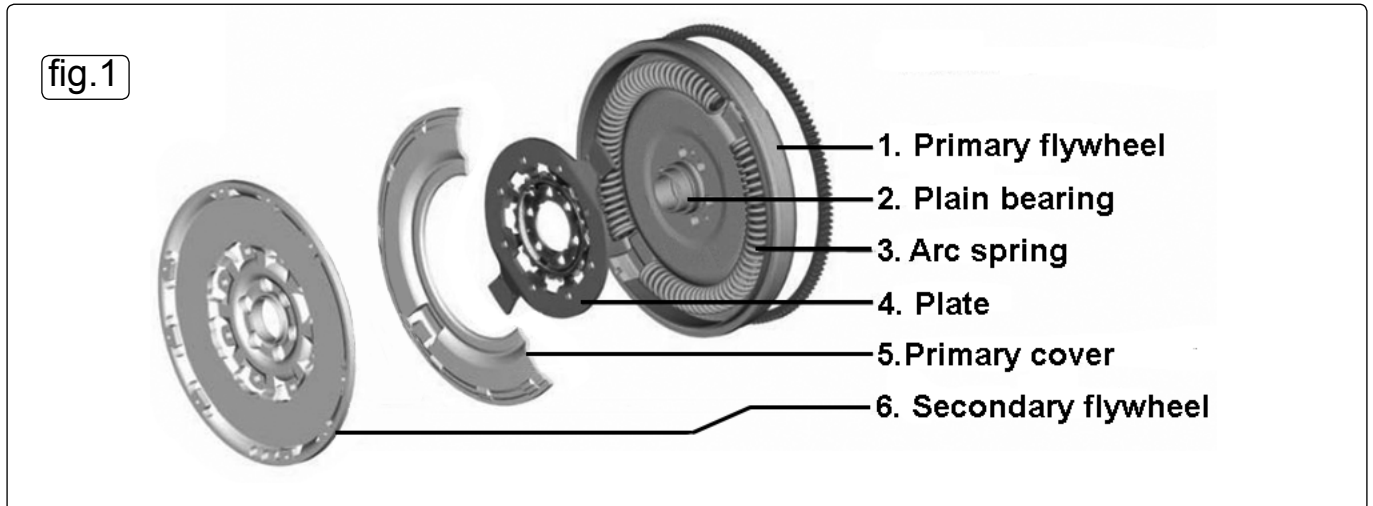

4.2 TEST 1: TESTING THE ROTATIONAL ARC SPRINGS/DAMPER SPRINGS FREE PLAY (Refer to figs. 2 & 3)

4.2.1 Attach the slotted bar (1) across the flywheel using the adaptors (2) supplied so that the angular torque gauge (3) is in the centre of the flywheel, see fig.2. If the flywheel has an odd amount of fixing screws, see fig.3, it is not possible to mount centrally and a reading will have to be taken by counting the ring gear teeth movement then working out the degrees of free play (see below).

4.2.2 Lock the flywheel using the Ring Gear Locking Tools (7) to stop the flywheel rotating under test. Spacers/washers may be required to align the locking tool with the ring gear.

4.2.3 Lightly (using the palm of your hand) turn the Slotted Bar (1) in either direction by the handle to find (start to compress) the Arc spring inside the flywheel. Then remove the pressure and allow the flywheel to return to the rest position. Zero the angular torque gauge (3) and lightly rotate in the opposite direction to find the opposite spring, then allow the flywheel to return to the rest position, then take a reading from the degree plate. When rotating, a thud may be heard which is common and not a faulty flywheel.

Note: The Arc springs are packed in grease, so a small amount of grease from the vent holes is normal but excessive grease will mean that the flywheel needs replacing.

4.3 TEST 2: TESTING THE CENTRE BEARING/BUSH FOR WEAR- ROCK (REFER to fig.4)

4.3.1 Fit DTI gauge (4) using the bracket provided (5) to the engine and locate the DTI tip onto one of the adaptors (2) that is holding the Slotted bar (1) onto the flywheel. Pre-load the DTI gauge, pull the slotted bar handle gently towards you and set the DTI gauge to zero. Then gently (using finger and thumb) rock the slotted bar handle back and forth to check the wear in the bush, taking the reading from the DTI. When checking for wear we are checking for rock **NOT** end float which on some flywheels is normal.

4.3.2 Once the two measurements have been taken, it is important to check the tolerance to the specific vehicle being worked on using the manufacturer's specifications. If the measurement exceeds the manufacturer's specifications the Dual Mass Flywheel will need to be replaced.

Examples of readings are: Maximum Freeplay 15° and Maximum Rock 1.6mm, but tolerances will vary depending on the vehicle being worked on.

Calculation for degrees rotation by counting the flywheel teeth (example)

If a flywheel has 112 teeth and freeplay is 4 teeth.
 $360\text{degrees}/112\text{teeth} = 3.214 \times 4 = 12.85 \text{ degrees}$

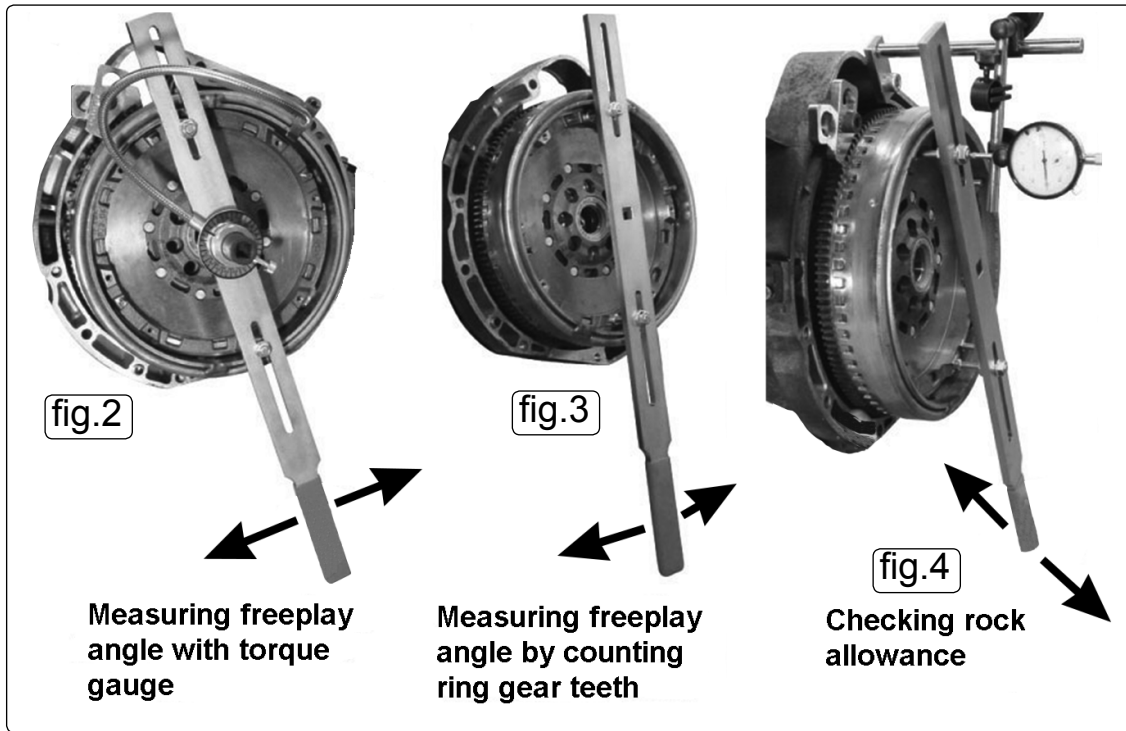

Parts support is available for this product. To obtain a parts listing and/or a diagram please log on to: www.sealey.co.uk, email: sales@sealey.co.uk or phone: 01284 757500



Environmental Protection.

Recycle unwanted materials instead of disposing of them as waste. All tools, accessories and packaging should be sorted, taken to a recycle centre and disposed of in a manner which is compatible with the environment.

NOTE: It is our policy to continually improve products and as such we reserve the right to alter data, specifications and component parts without prior notice.

IMPORTANT: No liability is accepted for incorrect use of this product.

WARRANTY: Guarantee is 12 months from purchase date, proof of which will be required for any claim.

INFORMATION: For a copy of our latest catalogue and promotions call us on 01284 757525 and leave your full name and address, including postcode.

SEALEY Professional TOOLS
Auto Service Line

Sole UK Distributor, Sealey Group, Kempson Way, Suffolk Business Park, Bury St. Edmunds, Suffolk, IP32 7AR

01284 757500



www.sealey.co.uk



01284 703534



sales@sealey.co.uk