



INSTRUCTIONS FOR: AUTOMATIC BRAKE & CLUTCH BLEEDER

MODEL NO: **VS0205**

Thank you for purchasing a Sealey product. Manufactured to a high standard this product will, if used according to these instructions and properly maintained, give you years of trouble free performance.



IMPORTANT: PLEASE READ THESE INSTRUCTIONS CAREFULLY. NOTE THE SAFE OPERATIONAL REQUIREMENTS, WARNINGS AND CAUTIONS. USE THIS PRODUCT CORRECTLY, AND WITH CARE FOR THE PURPOSE FOR WHICH IT IS INTENDED. FAILURE TO DO SO MAY CAUSE DAMAGE AND/OR PERSONAL INJURY AND WILL INVALIDATE THE WARRANTY. PLEASE KEEP INSTRUCTIONS SAFE FOR FUTURE USE.

1. SAFETY INSTRUCTIONS

- ✓ Keep this product in good working order and condition, take immediate action to repair or replace damaged parts.
- ✓ Use approved parts only. Unapproved parts may be dangerous and will invalidate the warranty.
- ✓ Keep children and unauthorised persons away from the work area.
- ✓ Keep work area clean and tidy and free from unrelated materials.
- ✓ Ensure the work area has adequate lighting.
- x **DO NOT** use the kit to perform a task for which it is not designed.
- x **DO NOT** allow untrained persons to use the kit.
- x **DO NOT** use when tired or under the influence of drugs, alcohol or intoxicating medication.
- ✓ After use, clean equipment and store in a cool, dry, childproof area.
- ✓ Dispose of waste liquids in accordance with local authority regulations.
- ✓ Always read and comply with the warnings on the brake fluid container.
- ✓ Wear eye protection and keep skin contact to a minimum. If brake fluid enters eyes rinse with plenty of water and seek medical advice. If swallowed seek medical advice immediately.
- ❑ **WARNING!** Only use new Brake Fluid, used Brake Fluid or other fluids will contaminate the system and possible brake system failure may result.
- ❑ **WARNING! DO NOT** pollute the environment by allowing uncontrolled discharge of fluids.
- ❑ **WARNING!** Brake fluid is flammable - keep away from sources of ignition, including hot surfaces e.g. exhaust manifold.
- ❑ **WARNING!** Brake fluid will damage paintwork. Any spillage should be flushed with water immediately.

2. INTRODUCTION

Fast, easy and effective bleeding of brakes and clutch using air from tyre. Innovative design incorporates valve for control of air pressure, extra-long air hose for use with larger vehicles and magnetic reservoir base to prevent accidental spillage. Suitable for use with ABS systems. Supplied with range of common adaptors.

Model No: VS0205
Maximum Air Supply: 20 psi

Accessories

- 1 x 25mm Cap and Seal for Lockheed Systems.
- 1 x 27mm Cap and Seal for VAG.
- 1 x 44/45mm Cap with 2 Seals
(1 x thin for 44mm Cap and 1 x thick for 45mm Cap) for metal Girling and ATE Systems
- 1 x 46mm Cap and Seal for some Girling Systems
- 2 x Bleed Pipes



3. OPERATION

3.1. Brake bleeding procedure.

Refer to the vehicle manufacturer's instructions for brake bleeding and wheel sequence before proceeding. If no specific instructions from the vehicle manufacturer exist, follow the instructions detailed below.

- ❑ **WARNING! Familiarise yourself with the hazards of brake fluid - read manufacturer's instructions on the container.**

NOTE: Ensure that the brakes are adjusted before proceeding with bleeding the brakes.

- 3.1.1. For vehicles fitted with servo assisted brakes, pump the brake pedal two or three times with the engine switched off to evacuate the air from the servo.
 - 3.1.2. Remove the reservoir cap from the vehicles brake master cylinder, select and fit, see fig.1, the appropriate adaptor cap to the automatic brake bleeder and connect to the master cylinder.
 - 3.1.3. Adjust the tyre pressure of one of the vehicles tyres or use a spare wheel to a maximum of 20 psi and connect the automatic brake bleeder.
 - 3.1.4. Pressure test the bottle with no brake fluid to ensure that the bottle has no leaks and then release the pressure, disconnect from the tyre and fill the pressure bottle with new clean brake fluid.
- ❑ **WARNING! DO NOT** overtighten the pressure bottle cap. Check that the seal is correctly seated in the cap before use and screw onto the pressure bottle until contact with the seal is achieved, tighten no more than 1/8th of a turn after this contact point.
 - 3.1.5. Ensure that the regulator (fig.2) on the top of the bottle is in the closed position connect the air line to the tyre. Ensure that the pressure bottle is in a safe upright position.
 - 3.1.6. Slowly open the regulator anti-clockwise to pressurise the brake system, checking to ensure there are no leaks.

NOTE: The 20 psi quoted is as a guide only, pressures as low as 10 psi can successfully bleed the brakes, adjust the regulator valve accordingly to the vehicle being worked on.

- 3.1.7. Starting from the bleed nipple furthest away from the master cylinder, attach a bleed tube and place the other end into a suitable container. Loosen the bleed nipple (fig.3) to allow the old brake fluid to flow into the container, when the fluid is clean and free from air re-tighten the nipple.
- 3.1.8. Repeat the operation for the remaining bleed nipples in the sequence recommended by the manufacturer.

NOTE: Ensure that the pressure bottle does not run out of brake fluid, if topping up is required, close the regulator and disconnect from the tyre, before replenishing the brake fluid.

- 3.1.9. When the bleeding operation is complete, disconnect from the tyre **BEFORE** removing from the brake master cylinder.
- 3.1.10. If required top up the brake fluid in the reservoir to the maximum level and replace the original reservoir cap.
- 3.1.11. Re-pressurise the tyre to its normal operating pressure.

NOTE: When brake bleeding and/or fluid changing is complete, test the action of the brake pedal to ensure that the brakes are working and are not spongy before using the vehicle on the road.

3.2. Tandem Master Cylinder Brake Systems.

- 3.2.1. Some vehicles require two lines to be bled simultaneously (normally one front and one rear), in this situation open both bleed nipples and control the flow using the regulator on the top of the pressure bottle.

3.3. Uncommon Brake Systems.

- 3.3.1. In some cases the master cylinder outlet is below the inlet, this may require pumping the pedal once or twice in conjunction with the pressure bleed to remove any trapped pockets of air. Alternatively the vehicle can be jacked up to raise the outlet.

3.4. Clutch bleeding procedure.

Refer to the relevant vehicle manufacturer's instructions for clutch bleeding procedure. If no specific instructions from the vehicle manufacturer exist, the same procedures as for brake bleeding should be followed.

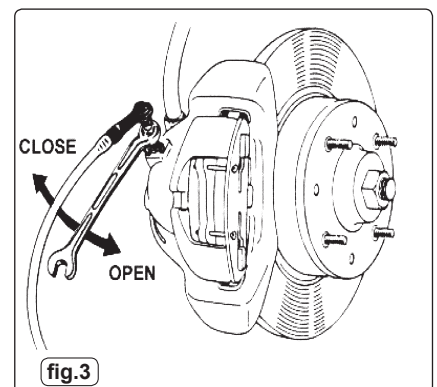
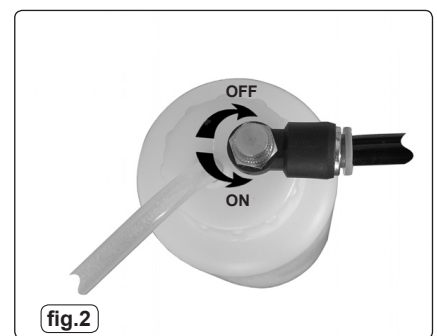
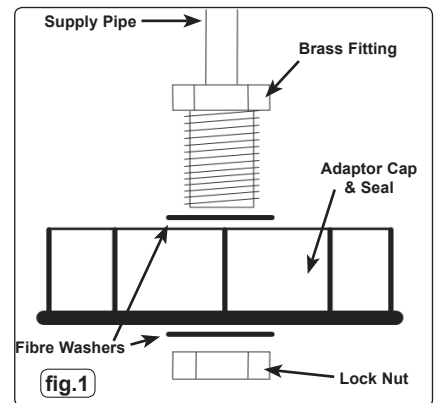

4. CLEANING & MAINTENANCE

- 4.1. Ensure that the unit is depressurised before carrying out any maintenance and drain all fluids from the pressure bottle and tubes. Clean up any spilt brake fluid and wipe down with a clean cloth. Store in a clean, dry and childproof location.

Parts support is available for this product. To obtain a parts list and diagram please log on to www.sealey.co.uk, email sales@sealey.co.uk or phone 01284 757500

NOTE: It is our policy to continually improve products and as such we reserve the right to alter data, specifications and component parts without prior notice.

IMPORTANT: No liability is accepted for incorrect use of this product.

WARRANTY: Guarantee is 12 months from purchase date, proof of which will be required for any claim.

INFORMATION: For a copy of our catalogue and latest promotions call us on 01284 757525 and leave your full name, address and postcode.



Sole UK Distributor, Sealey Group,
Kempson Way, Suffolk Business Park,
Bury St. Edmunds, Suffolk,
IP32 7AR

01284 757500

01284 703534



www.sealey.co.uk



sales@sealey.co.uk