

Thank you for purchasing a Sealey product. Manufactured to a high standard this product will, if used according to these instructions and properly maintained, give you years of trouble free performance.

IMPORTANT: PLEASE READ THESE INSTRUCTIONS CAREFULLY. NOTE THE SAFE OPERATIONAL REQUIREMENTS, WARNINGS AND CAUTIONS. USE THE PRODUCT CORRECTLY AND WITH CARE FOR THE PURPOSE FOR WHICH IT IS INTENDED. FAILURE TO DO SO MAY CAUSE DAMAGE AND/OR PERSONAL INJURY AND WILL INVALIDATE THE WARRANTY. PLEASE KEEP INSTRUCTIONS SAFE FOR FUTURE USE.

1. SAFETY INSTRUCTIONS

- ❑ **WARNING! Ensure Health and Safety, local authority and general workshop practice regulations are adhered to when using tools.**
- ❑ **WARNING! Always use caution when working around fuel systems. The fuel in the fuel rail may be pressurised even if the engine is not running.**
- ❑ **IMPORTANT: These instructions are provided as a guide only. Always refer to the vehicle manufacturer's service instructions, or a proprietary manual, to establish the current procedure and data, also any warnings or cautions particular to the vehicle.**
- x **DO NOT** use the set if any parts are missing or damaged.
- x **DO NOT** use this tool for any purpose other than that for which it is designed.
- ✓ Switch off vehicle's ignition and disconnect the battery before commencing work under the bonnet.
- ✓ You must follow the vehicle's service manual cautions when working around the air bag system. If the cautions are not followed the air bag may deploy unexpectedly even after the ignition is turned 'OFF', resulting in personal injury.
- x Never lay tools on the vehicle's battery. This may short the terminals together, causing harm to yourself, the tools, or the battery.
- ✓ Operate in a well ventilated area. Do not inhale fuel vapours.
- ✓ Wear approved eye protection. A full range of personal safety equipment is available from your Sealey dealer.
- ✓ Wear suitable clothing to avoid snagging. Do not wear jewellery and tie back long hair.
- ✓ Keep children and other unauthorised persons away from the working area.
- ✓ Keep yourself, tools, and test equipment away from hot engine parts.
- ✓ Always keep a fire extinguisher close by, that is suitable for fuel/electrical/chemical fires.
- x **NEVER** smoke or have open flames near vehicle.
- ✓ Always relieve fuel pressure before disconnecting fuel lines from injectors.
- ✓ Use a rag to cover fuel line fittings, when connecting or disconnecting fuel lines. Avoid contact with fuel.
- ✓ Clean up all fuel spills immediately and dispose of all rags properly.
- ✓ Maintain the tool components in good and clean condition for best and safest performance.
- ✓ When work on the vehicle is finished, ensure all connections on vehicle are restored, and that there are no tools left in the engine bay.
- ✓ Replace tools in the carrying case and store in a safe, dry, childproof location.

2. INTRODUCTION & CONTENTS

Suitable for the fast and safe removal of Bosch, Delphi, Denso, and Siemens diesel injectors. Set includes keys and deep, open profile sockets used to dismantle injectors plus adaptors for attaching the slide hammer securely to the body of the injector. Ball joint allows hammer to be used in confined areas.

Contents: (refer to fig.1)

| Item | Description |
|------|--|
| 1 | Sliding Hammer |
| 2 | Handle |
| 3 | Shaft |
| 4 | Ball Joint Adaptor (3 piece) |
| 5 | Adaptors - (5 Pieces - 4 internal thread, 1 external thread) |
| 6 | External Adaptor - (3 piece) |
| 7 | Security Hex Key - 1/2"sq. drive |
| 8 | Sockets - (4 pieces - M25, M27, M29, M30 - 1/2"sq. drive) |

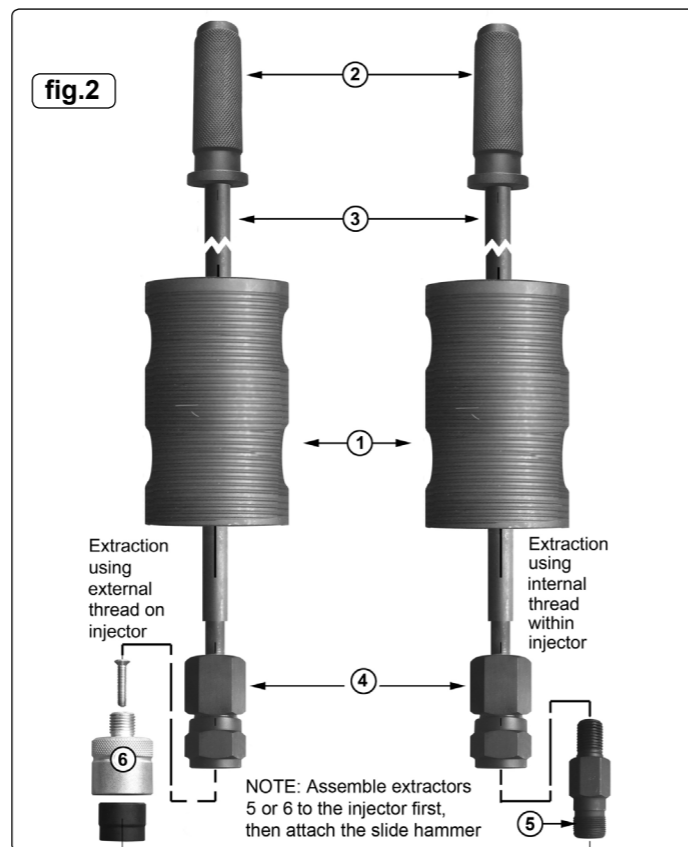
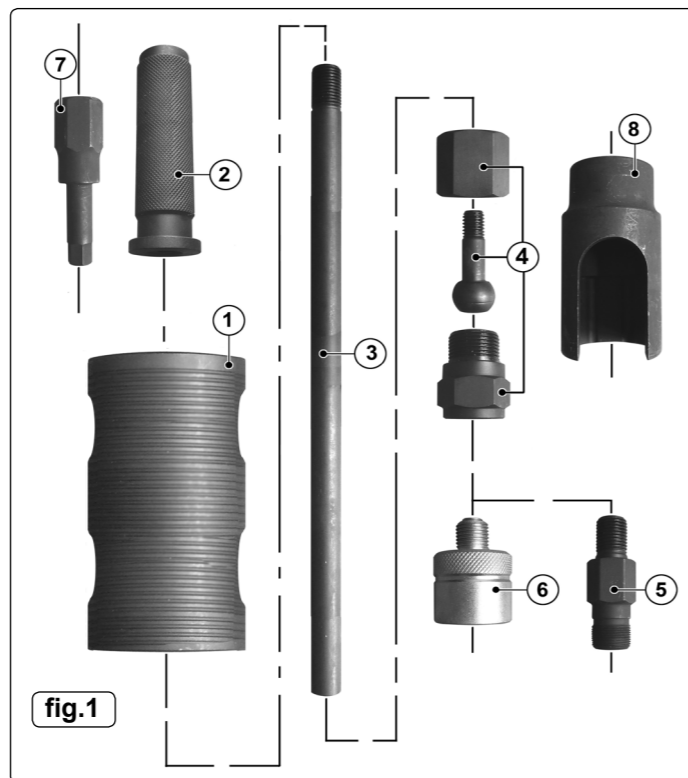

3. ASSEMBLY

- 3.1. Referring to the individual components in fig.1. assemble the Injector Puller as shown in fig.2. overleaf.
- 3.2. Use adaptor 6 when the injector is being extracted using the external thread revealed when the injector cap has been removed.

4. OPERATION

- NOTE: The technique required for removal of the injector will depend on which system is fitted to the vehicle. Always use an external adaptor first if possible. If by using reasonable force the injector cannot be removed, use an internal adaptor.**
- 4.1. Before working on the fuel system, make sure that the fuel system is **NOT** pressurised. Refer to the manufacturer's instruction manual on how to de-pressurise the system.
 - 4.1.1. Disconnect the injector wires and connections as per the manufacturer's instructions.
 - 4.1.2. Remove any carbon build up from around the injector.
 - 4.1.3. Remove the cap from the injector using the appropriate size socket (8). Refer to fig.3.A.
 - 4.2. **Use of external adaptor (fig.3).**
 - 4.2.1. Identify the external thread adaptor (6) and separate the inner black part from the outer silver part by removing the screw from the top of the adaptor.
 - 4.2.2. Position the black part inside the top of the injector (see B) then place the silver part over it, and screw it down firmly onto the external threads revealed when the cap was removed.
 - 4.2.3. Install the screw securely thus locking the adaptor parts tightly together with the injector thread and wall in between. This ensures a more secure fastening and reduces damage to the injector threads.

- 3.3. Use one of the adaptors (5) when the injector is being extracted using the internal thread revealed when the inner sleeve has been removed from the injector.

- 4.3. **Use of internal adaptor (fig.4).**
 - 4.3.1. Remove the internal parts from the injector to gain access to the security hex key (7). It may be necessary to remove the injector veins by force. Insert the security hex into the inner sleeve (see D). Turn the security hex anti-clockwise using a 21mm socket to remove the inner sleeve.
 - 4.3.2. Screw the appropriate internal adaptor (5) into the threads of the injector and tighten with a suitable spanner (see E).
- 4.4. **Removing the injector.**
 - 4.4.1. Screw the slide hammer assembly (handle, shaft and sliding hammer) securely onto the adaptor.
 - 4.4.2. The injector can now be removed using reasonable force on the slide hammer. Be prepared for the sudden release of the injector from the cylinder head.
 - 4.4.3. If the injector cannot be removed, it may be necessary to consult a main dealer or a diesel specialist, to avoid damage to the engine.
 - 4.4.4. When an injector has been removed, it is recommended that only a new or refurbished injector is fitted. Follow manufacturers fitting and safety instructions.

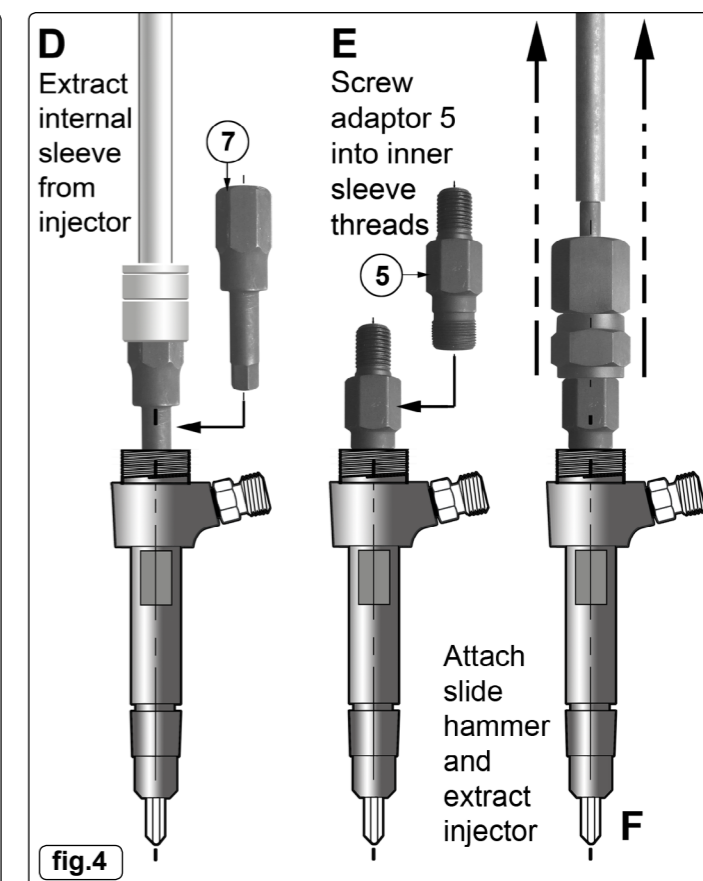
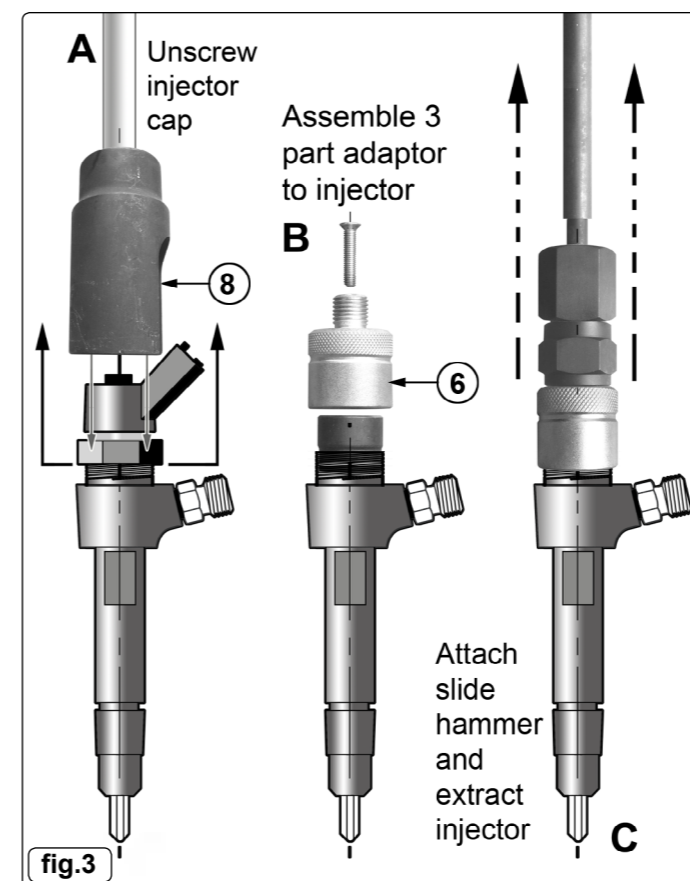

NOTE: It is our policy to continually improve products and as such we reserve the right to alter data, specifications and component parts without prior notice.
IMPORTANT: No liability is accepted for incorrect use of this product.
WARRANTY: Guarantee is 12 months from purchase date, proof of which will be required for any claim.
INFORMATION: For a copy of our latest catalogue and promotions call us on 01284 757525 and leave your full name and address, including postcode.