

Thank you for purchasing a Sealey product. Manufactured to a high standard, this product will, if used according to these instructions, and properly maintained, give you years of trouble free performance.

**IMPORTANT:** PLEASE READ THESE INSTRUCTIONS CAREFULLY. NOTE THE SAFE OPERATIONAL REQUIREMENTS, WARNINGS & CAUTIONS. USE THE PRODUCT CORRECTLY AND WITH CARE FOR THE PURPOSE FOR WHICH IT IS INTENDED. FAILURE TO DO SO MAY CAUSE DAMAGE AND/OR PERSONAL INJURY AND WILL INVALIDATE THE WARRANTY. KEEP THESE INSTRUCTIONS SAFE FOR FUTURE USE.



Refer to instructions



Wear protective gloves



Wear eye protection

## 1. SAFETY

- ✓ Keep this product in good working order and condition, take immediate action to repair or replace damaged parts.
- ✓ Use approved parts only. Unapproved parts will invalidate the warranty.
- ✓ Keep children and unauthorised persons away from the work area.
- ✓ Keep work area clean and tidy and free from unrelated materials.
- ✓ Ensure the work area has adequate lighting.
- ✗ **DO NOT** use the kit to perform a task for which it is not designed.
- ✗ **DO NOT** hold pump inlet against the skin whilst using the pump.
- ✗ **DO NOT** allow untrained persons to use the kit.
- ✗ **DO NOT** use whilst under the influence of drugs, alcohol or intoxicating medication.
- ✓ After use, clean equipment and store in a cool, dry, childproof area.
- ❑ **WARNING!** Brake fluid will damage paintwork. Any spillage should be flushed with water immediately.
- ❑ **WARNING!** Brake fluid is flammable - keep away from sources of ignition, including hot surfaces e.g. exhaust manifold.
- ✓ Dispose of waste liquids in accordance with local authority regulations.
- ❑ **WARNING! DO NOT** pollute the environment by allowing uncontrolled discharge of fluids.
- ✓ Always read and comply with the warnings on the brake fluid container.
- ✓ Wear eye protection and keep skin contact to a minimum. If brake fluid enters eyes rinse with plenty of water and seek medical advice. If swallowed seek medical advice immediately.

## 2. INTRODUCTION

The VS402 vacuum tester and brake bleeding kit is a multi-function diagnostic tool used to test a variety of essential engine and associated functions including fuel, ignition, transmission and emissions. Set also includes reservoir, hoses and adaptors for bleeding brake and clutch systems on cars, commercials and motorcycles. Brass-bodied vacuum pump features large, easy-to-read vacuum gauge calibrated in both inches and millimetres of mercury.

## 3. CONTENTS

ITEM	PART No.	DESCRIPTION	ITEM	PART No.	DESCRIPTION
1	VS402.V3-01	VACUUM PUMP WITH GAUGE	6	VS402.V3-06	HOSE ADAPTOR
2A	VS402.V3-02A	RESERVOIR LID (FOR OPERATION)	7	VS402.V3-07	HOSE ADAPTOR 'T-PIECE'
2B	VS402.V3-02B	RESERVOIR LID (FOR TRANSPORT)	8	VS402.V3-08	HOSE ADAPTOR 'STRAIGHT'
3	VS402.V3-03	RESERVOIR JAR	9	VS402.V3-09	BRAKE BLEED NIPPLE ADAPTOR
4	VS402.V3-04	560mm VACUUM HOSE	10	VS402.V3-10	UNIVERSAL CUP ADAPTOR
5	VS402.V3-05	80mm VACUUM HOSE			

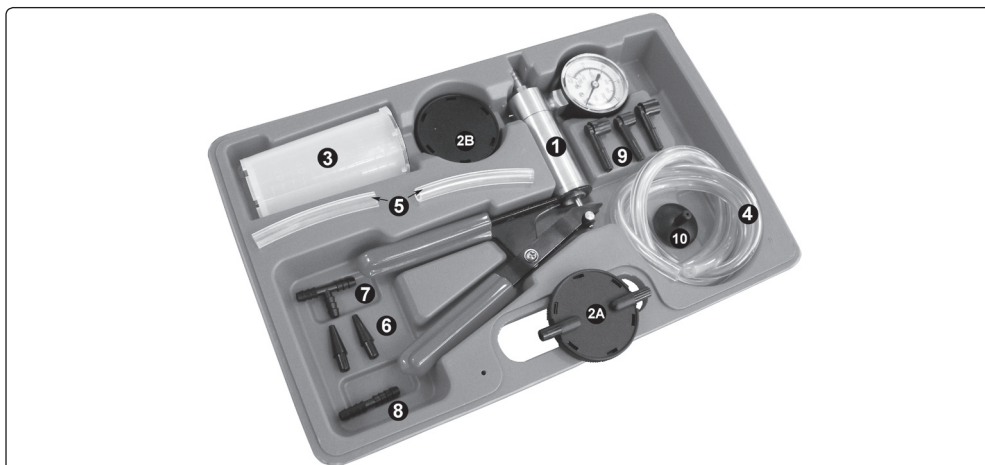

## 4. OPERATION

The use of a vacuum gauge is often overlooked when determining mechanical condition and carrying out fault diagnosis on internal combustion engines. Monitoring actual manifold vacuum is invaluable when troubleshooting engine faults. This can only be carried out by using a good quality vacuum gauge and this, coupled with a hand-operated vacuum pump, also allows static testing of all types of vacuum operated systems. Set out on the following pages are applications that the VS402 vacuum tester kit can be used for, but it must always be remembered that these are examples only and reference to manufacturer's service manuals should always be made for correct testing procedures and specifications. In addition to this, it is always recommended that additional tests, i.e. compression tests, cylinder leakage tests, ignition timing checks etc. be carried out to confirm indications of vacuum gauge readings.

## 5. INLET MANIFOLD SYSTEMS

### 5.1. Analysing Engine Mechanical Condition via Manifold Vacuum Readings

5.1.1. The readings shown below are only examples of what may be observed.

It is important to remember that it is the action of the needle rather than the actual reading that is more important. Varying engine types will run different manifold vacuum pressures, depending on camshaft profile, valve overlap, timing etc. so an exact vacuum reading cannot be specified. The main criteria is that the needle reading is between 16 to 21 inHg and steady.

5.1.2. Manifold vacuum is also affected by altitude and it will drop approximately 1 inHg for every 1000 feet above sea level so this must also be considered when assessing manifold vacuum actual readings.

### 5.2. Basic Diagnostic Tests

5.2.1. Carry out the following procedures:

Step 1. Run engine until normal operating temperature is reached. Switch engine off.

Step 2. Connect the vacuum gauge to a port directly on the manifold (fig.1) or on the carburettor/throttle body below the throttle butterfly.

Step 3. Start and run the engine at idle, observing the gauge reading.

Refer to the following table to indicate any problems and their possible causes.

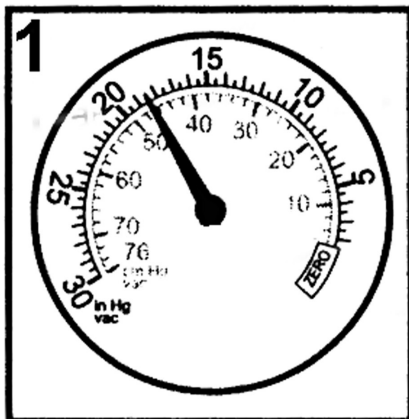
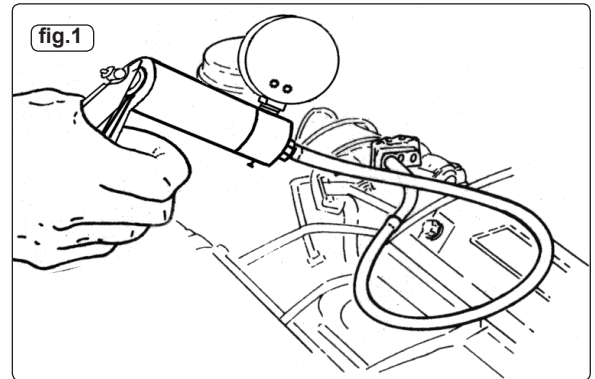

**READING:** 16-21 in Hg with needle steady.  
**CAUSE:** Normal

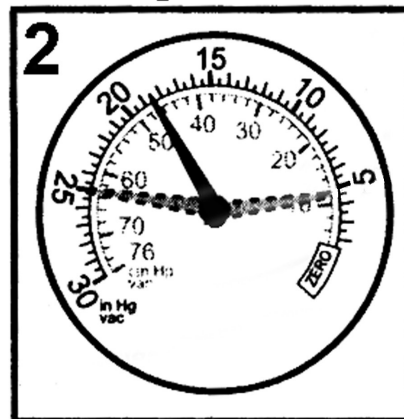

**READING:** When the throttle is suddenly opened then released the needle should drop to below 5 inHg then bounce up to approx. 25 inHg settling back to original reading.  
**CAUSE:** Normal

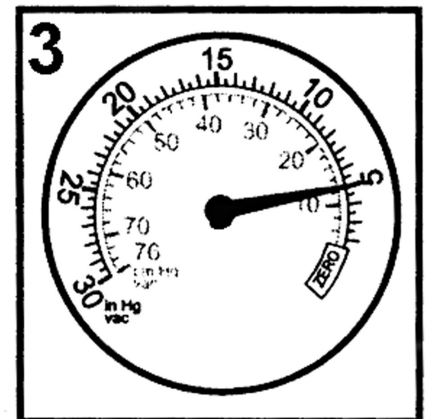

**READING:** Reading extremely low but steady.  
**CAUSE:** Leaking manifold intake system, faulty manifold gasket, carburettor base gasket, split vacuum hose, EGR valve seized.

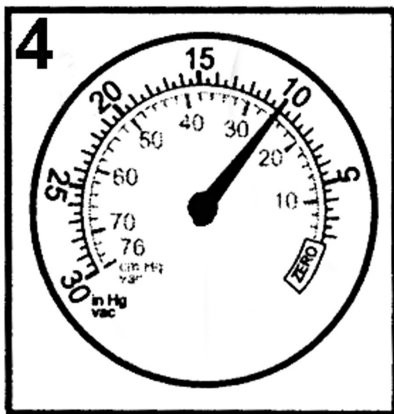

**READING:** Reading low but steady.  
**CAUSE:** Retarded ignition timing. Confirm using timing light and reset to manufacturer's specification.

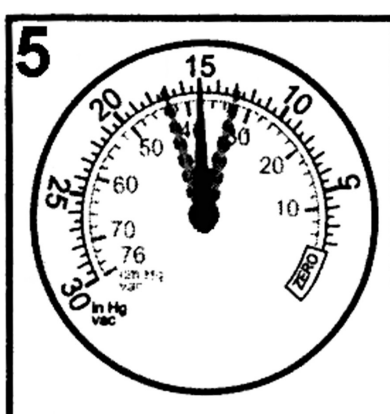

**READING:** Reading slightly low and fluctuating slowly.  
**CAUSE:** Over lean or rich mixture. Check and reset in accordance with manufacturer's specifications.

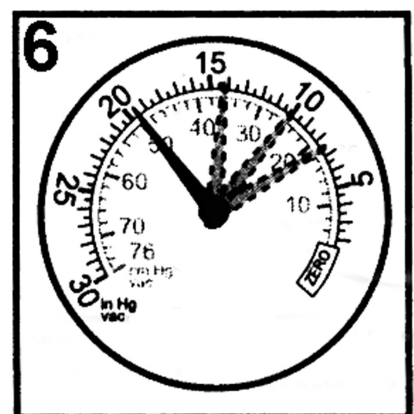

**READING:** Regular fluctuation between normal and low readings.  
**CAUSE:** Blown cylinder head gasket between two adjacent cylinders. Carry out cylinder leakage test.

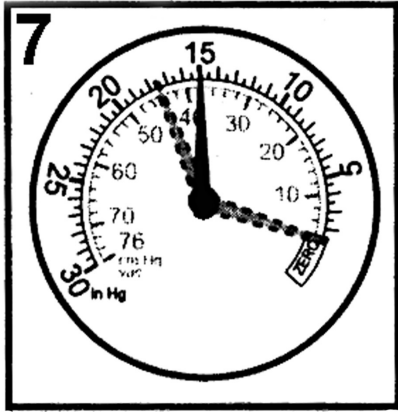

**READING:** Readings slightly lower than for lower for normal engine including when throttle is suddenly opened then released.  
**CAUSE:** Worn piston rings. Carry out compression test.

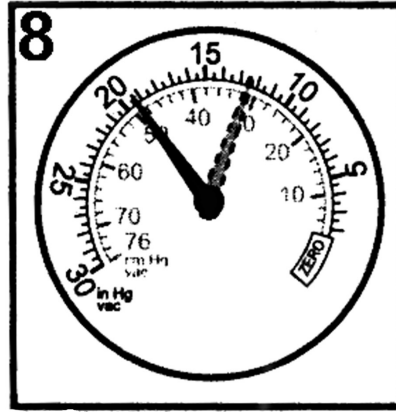

**READING:** Regular drop between normal and low reading.  
**CAUSE:** Burnt valve.

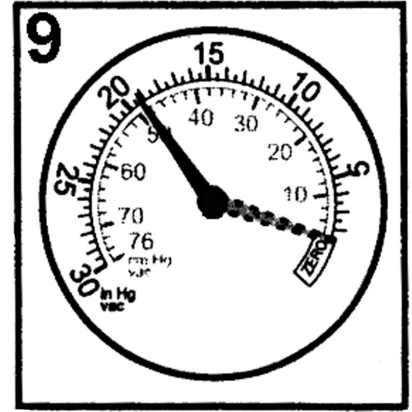

**READING:** Normal when first started but drops rapidly when revs held at 3000rpm.  
**CAUSE:** Restriction in exhaust system.

### 5.3. Ignition system vacuum advance

- 5.3.1. On standard points systems and some electronic ignition systems there are two types of advance methods used, both of which must function correctly to obtain maximum performance and fuel economy.
- 5.3.2. The first method is Mechanical or Centrifugal, which operates by the use of weights located in the base of the distributor. The weights move outwards advancing ignition timing as engine RPM increases. This is tested by firstly removing the vacuum advance line to disable the system, then with a timing light connected, run the engine RPM up checking that the timing advances in accordance with the manufacturer's specification.
- 5.3.3. The second method is Vacuum Advance, which senses engine load via manifold vacuum. A vacuum diaphragm is mounted onto the distributor and connected to a rotating internal base plate which advances or retards timing as required to suit varying engine loads. To test this system for correct operation, again with the timing light connected, raise the engine RPM and check timing advance against manufacturer specifications. In the event that the vacuum advance is not operating, remove the vacuum line from the distributor advance mechanism. Connect the VS402 (fig.2) and create a 5-10inHg vacuum, monitoring the timing at the same time. If a timing advance is noted this confirms that the vacuum diaphragm and mechanical links are in order and that the fault is a vacuum supply. To confirm this, connect the VS402 to the vacuum supply line and check the gauge reading. No vacuum should be noted at idle but when the engine RPM is increased a vacuum increase should be observed. If this does not occur, trace the vacuum line back checking for restrictions and breaks.

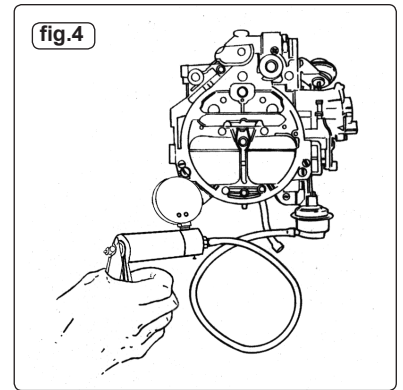
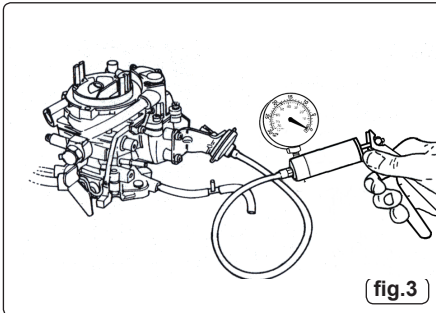
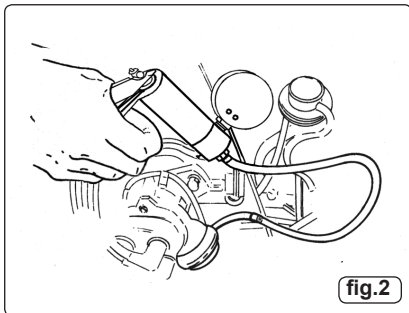

## 6. FUEL SYSTEMS

### 6.1. Testing Mechanical Fuel Pumps

- 6.1.1. The VS402 vacuum tester can be used to evaluate the condition of a mechanical fuel pump by testing the vacuum that it is able to create. Locate and remove the suction line from the pump. Connect the VS402 vacuum tester to the suction port of the pump, start and run the engine at idle. The vacuum reading that should be observed will vary slightly on different makes and models but as a general rule approximately 15inHg of vacuum should be created. This should also be held for approximately 1 minute after engine shut down. If this vacuum reading is not achieved or the vacuum drops off immediately with the engine shut down, the fuel pump requires either overhaul or replacement.

### 6.2. Carburettors

- 6.2.1. There are many different types of vacuum control systems used on carburettors. Using the VS402 vacuum tester kit allows quick and accurate testing of these systems. Listed below are just two examples of tests that can be carried out:
- 6.2.2. Testing a Choke Break Diaphragm. With the engine at normal operating temperature but not running, disconnect the vacuum line to the diaphragm module. Connect the VS402 vacuum tester (fig.3) and apply approximately 15inHg of vacuum and wait for 30 seconds. No drop in gauge reading should be observed. With the vacuum still applied ensure that the choke butterfly is pulled to the fully open position.
- 6.2.3. Testing Vacuum Operated Carburettor Secondary Barrel. With the engine at normal operating temperature but not running, remove the vacuum line from the secondary diaphragm module. Connect the VS402 vacuum tester (fig.4), hold the throttle and secondary air valve flaps open. Operate the hand pump whilst observing free and easy opening of the secondary throttle butterfly.

### 6.3. Testing Fuel Injection Pressure Regulator

- 6.3.1. Multi-point fuel injection rail pressure must vary to suit changing engine loads and fuel delivery requirements. This is done using a vacuum operated regulator which is connected to the engine manifold vacuum to sense the varying loads.
- 6.3.2. To test the fuel rail pressure, a gauge is attached to the rail, then engine loads must be created to vary engine manifold vacuum. Simply



remove and block off the vacuum supply line to the pressure regulator, connect and operate the VS402 vacuum pump (fig.5) to simulate vacuum pressures in accordance with the manufacturer's specifications and note variation in fuel pressure reading.

#### 6.4. Testing Emission Control Exhaust Gas Recirculation Valves (EGR)

6.4.1. Start engine and run at idle until normal operating temperature is reached. Remove the vacuum line from the EGR valve and attach the VS402 vacuum tester kit (fig.6). Operate the hand pump to apply approximately 15inHg of vacuum. If the EGR Valve is working correctly the engine idle will become rough. If the idle remains unchanged the valve is possibly seized in the closed position. If the vacuum is not held, the diaphragm in the valve has failed.

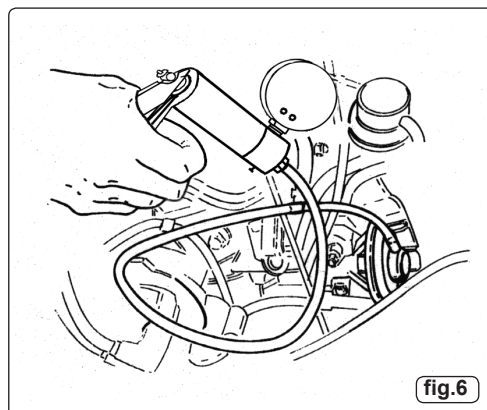
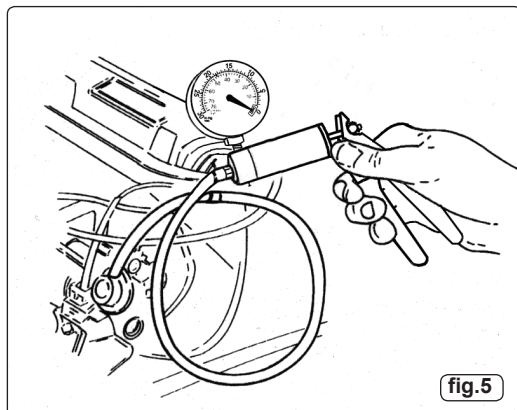

## 7. ADDITIONAL VACUUM SYSTEMS

### 7.1. Testing One-Way Valves

7.1.1. Many vacuum operated circuits use in-line one-way valves to apply vacuum in one direction only.

7.1.2. To test the function of the valve remove it from the circuit. Attach the VS402 vacuum tester (fig.7) and operate pump to apply vacuum. In one direction the valve should hold vacuum and in the opposite direction it should not.

### 7.2. Testing Electrically Operated Vacuum Solenoids

7.2.1. Electrically operated vacuum solenoids are commonly used in control circuits for air conditioning/ventilation systems, emission control systems, idle step up systems etc. and testing the function of these when using the VS402 is extremely simple.

7.2.2. Locate the solenoid to be tested and remove the line that goes to the component being tested. Connect the VS402 to the solenoid port (fig.8) and start the engine. With the system turned off there should be a zero gauge reading. Now turn the system to the 'on' position and a gauge reading equal to the manifold vacuum should be observed, if no reading exists remove the vacuum supply line and test for manifold vacuum at this point. If the vacuum does exist this indicates that the solenoid is faulty or it is not receiving a 'switch on' voltage (use a multimeter to test this). If no vacuum exists trace the supply line back to the vacuum source checking for kinks and breaks.

### 7.3. Testing Thermal Vacuum Switches

7.3.1. There are many vacuum controlled circuits that must only operate when the engine reaches normal operating temperature. This is done using thermal switches that remain in an 'off' position until a given temperature is reached.

7.3.2. To test this type of switch, remove the vacuum supply line coming from the manifold to the switch and test for manifold vacuum. If this vacuum is correct refit the supply line to the thermal switch and remove the opposing line from the switch. Attach the VS402 vacuum tester to the port (fig.9) and start the engine. With a cold engine no reading should be noted. When the engine reaches normal operating temperature a manifold vacuum reading should be noted.

### 7.4. Testing Vacuum Operated Heater Taps

7.4.1. Climate control ventilation systems are becoming very common on newer vehicles and most of the systems use vacuum operated taps to control the heating modes. On the majority of makes and models, the system uses vacuum to turn the heater tap 'on'.

7.4.2. To test these remove the supply line from the tap vacuum module and connect the VS402 vacuum tester (fig.10). With the engine at normal operating temperature locate and feel the heater return hose. With the heater tap in the 'off' position, this hose should be cold. Now operate the vacuum pump to open the tap. The gauge reading must hold. If the tap is in working order, the return hose will begin to heat. If the hose does not begin to heat, this indicates that the tap is faulty.

### 7.5. Testing Vacuum Operated Remote Central Locking Systems

7.5.1. Some makes and models use vacuum operated bellows mounted in each door to centrally lock and unlock the vehicles doors. These systems use either manifold vacuum stored in a reservoir for use when the engine is not running or an electrically driven vacuum pump which operates when the doors are locked or unlocked.

7.5.2. In either system, the VS402 vacuum tester is ideal for testing each individual door bellows. To do this, remove the door trims as required. Remove the vacuum supply lines from the bellows and attach the VS402 vacuum tester (fig.11) and operate to apply vacuum to the bellows. Wait for 30 seconds, no drop on the gauge should be noted. If the bellows are found to be in order attach the vacuum supply line to the VS402 vacuum tester and operate system to test for vacuum supply. If the vacuum supply does not exist or is low trace back down the lines to the vacuum supply looking for kinks, restrictions or cracked lines. Repair as required and retest.

### 7.6. Testing Automatic Transmission Vacuum Operated Modulator Valves

7.6.1. Automatic transmissions are normally equipped with a vacuum operated modulator valve in order for the automatic transmission to detect engine loads and adjust shift points to suit.

7.6.2. The VS402 vacuum tester can be used to test both that the modulation valve diaphragm is serviceable and also to simulate varying engine loads so modulator pressure readings can be recorded. To test the modulator valve diaphragm remove the vacuum supply line from the valve and attach the VS402 vacuum tester. Operate the vacuum pump until approximately 15inHg is achieved and monitor the gauge reading for approximately 30 seconds. No vacuum drop should be noted.

7.6.3. To check modulator pressure readings attach a pressure gauge to the appropriate port on the transmission. Remove the vacuum supply line from the modulator and attach the VS402 vacuum tester (fig.12). Start and run the engine and apply vacuum pressures. Monitor readings and confirm that these are in conformance with manufacturer specifications.

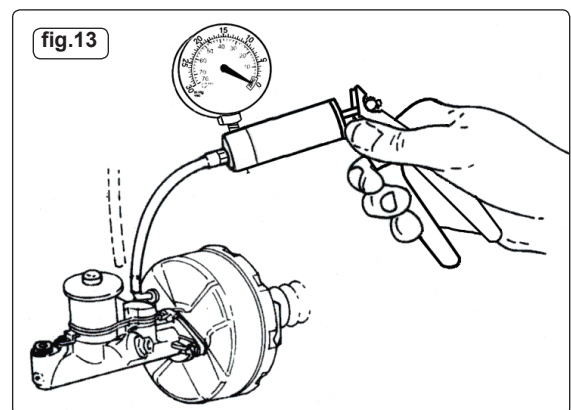
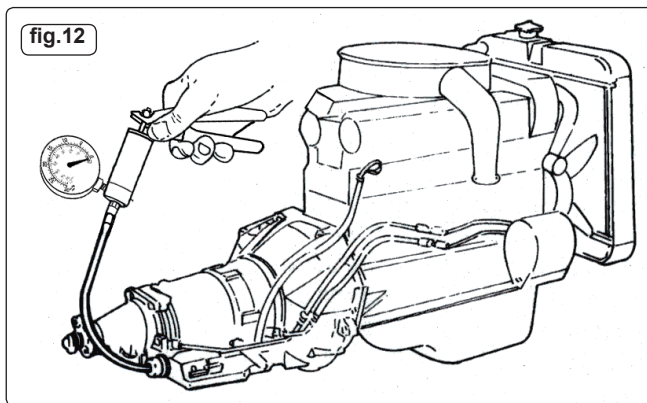
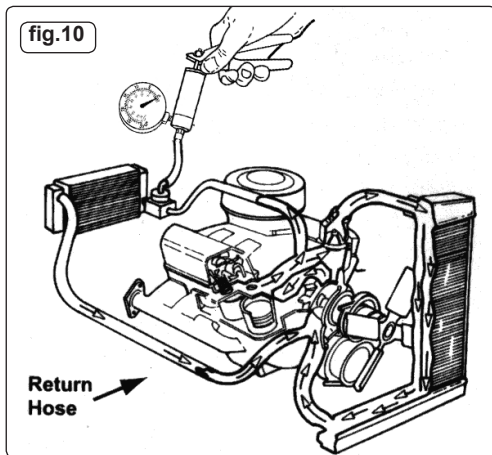
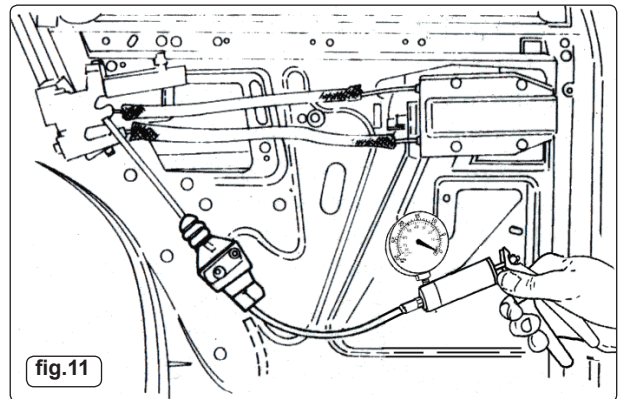
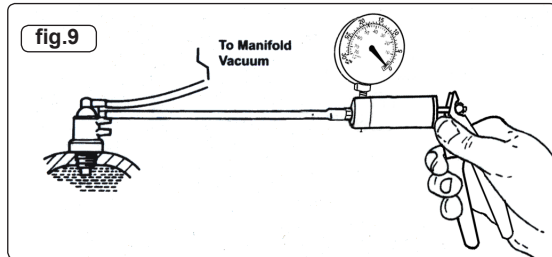
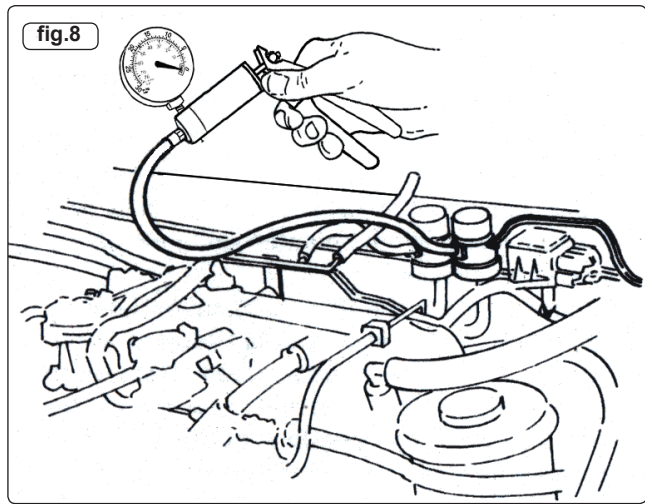
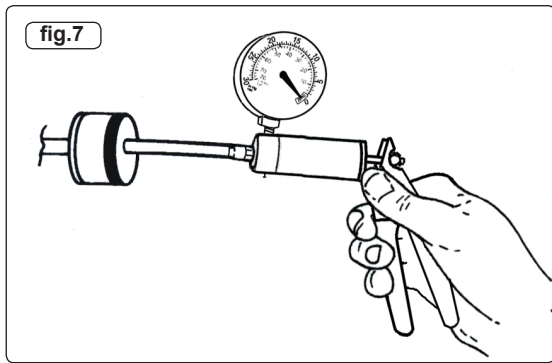

## 8. BRAKING SYSTEMS

### 8.1. Testing Brake Servo Diaphragm

8.1.1. Remove vacuum supply line from brake servo fitting. Attach VS402 vacuum tester to vacuum supply port on servo (fig.13). Operate pump to create approximately 15inHg of vacuum and wait for 30 seconds. No vacuum drop should be observed on the gauge reading. If the vacuum drops this indicates that the brake servo diaphragm is faulty. In this case the servo should be removed for overhaul by an authorised repairer or replaced.

### 8.2. Brake Bleeding - Assembly of Brake Bleeder Kit

8.2.1. Ensure that the vacuum pump is connected to the brake bleeder reservoir in accordance with the assembly diagram (fig.14). Failure to do so will result in brake fluid being drawn into the vacuum pump.

### 8.3. Brake Bleeding Procedure.

- WARNING!** Familiarise yourself with the hazards of brake fluid - read manufacturer's instructions on the container. **DO NOT** touch the vehicle's brake pedal whilst bleeding the brakes.

8.3.1. Refer to the specific vehicle manufacturer's instructions for brake bleeding and wheel sequence procedure before proceeding. If no specific instructions from the vehicle manufacturer exist, follow the instructions detailed below.

8.3.2. Remove the cap of the vehicle's master brake fluid reservoir. If the fluid level is not at maximum, top it up.

8.3.3. Attach the appropriate size bleeding attachment to the bleed nipple on the brake calliper of the first wheel, normally nearest to master brake fluid reservoir.

- 8.3.4. Operate vacuum pump until approximately 21inHg vacuum is created.
- 8.3.5. Apply copper grease to the brake bleeding nipples before and after the brake bleeding procedure to reduce the possibility of seized or broken nipples when the brakes are next bled.
- 8.3.6. Open the bleed nipple about a quarter of a turn. Allow brake fluid to be drawn until no air bubbles are visible in the brake fluid in the clear hose.
- 8.3.7. Tighten the bleed nipple.
- 8.3.8. Remove the attachment from the brake nipple.
- 8.3.9. Repeat the process as necessary.

**NOTE!** Check the master brake fluid reservoir regularly to ensure that the level does not drop too far, and top up as necessary.

**NOTE!** Empty bleeder container regularly and **DO NOT** allow container to overfill as brake fluid will be drawn into vacuum pump.

- **WARNING!** When brake bleeding and/or fluid changing is complete, test the action of the brake pedal to ensure that the brakes are working before attempting to drive the vehicle on the road and test the vehicle for satisfactory performance of the braking system.

**8.4. Clutch Bleeding Procedure.**

- 8.4.1. Refer to the relevant vehicle manufacturer's instructions for clutch bleeding procedure. If no specific instructions from the vehicle manufacturer exist, follow the same basic procedure as the brake bleeding instructions above.

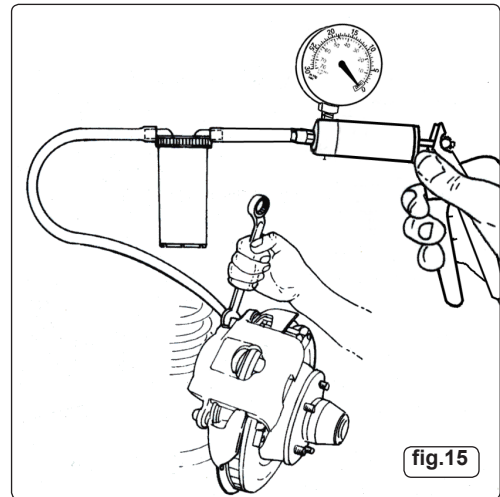
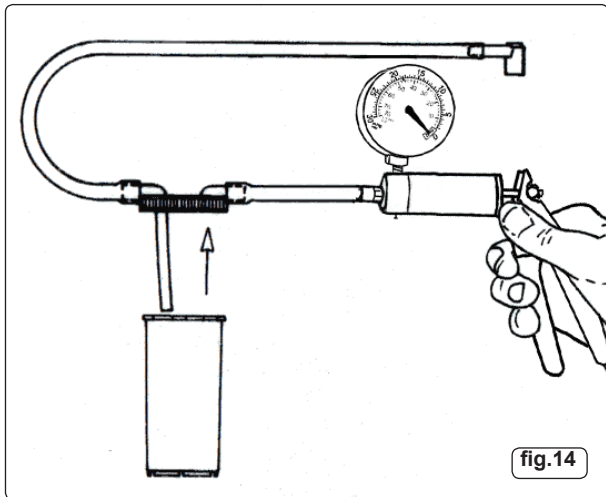

**Environmental Protection**

Recycle unwanted materials instead of disposing of them as waste. All tools, accessories and packaging should be sorted, taken to a recycling centre and disposed of in a manner which is compatible with the environment. When the product becomes completely unserviceable and requires disposal, drain off any fluids (if applicable) into approved containers and dispose of the product and the fluids according to local regulations.

**NOTE:** It is our policy to continually improve products and as such we reserve the right to alter data, specifications and component parts without prior notice.

**IMPORTANT:** No liability is accepted for incorrect use of this product.

**WARRANTY:** Guarantee is 12 months from purchase date, proof of which will be required for any claim.



Sole UK Distributor, Sealey Group.  
Kempson Way, Suffolk Business Park,  
Bury St. Edmunds, Suffolk.  
IP32 7AR



01284 757500



01284 703534



www.sealey.co.uk



sales@sealey.co.uk