

Thank you for purchasing a Sealey product. Manufactured to a high standard this product will, if used according to these instructions and properly maintained, give you years of trouble free performance.



IMPORTANT: PLEASE READ THESE INSTRUCTIONS CAREFULLY. NOTE THE SAFE OPERATIONAL REQUIREMENTS, WARNINGS AND CAUTIONS. USE THE PRODUCT CORRECTLY AND WITH CARE FOR THE PURPOSE FOR WHICH IT IS INTENDED. FAILURE TO DO SO MAY CAUSE DAMAGE AND/OR PERSONAL INJURY, AND WILL INVALIDATE THE WARRANTY. PLEASE KEEP INSTRUCTIONS SAFE FOR FUTURE USE.

1. SAFETY INSTRUCTIONS

- ❑ **WARNING!** Ensure Health and Safety, local authority and general workshop practice regulations are adhered to when using tools.
 - x **DO NOT** use tools if damaged.
 - ✓ Maintain tools in good and clean condition for best and safest performance.
 - ✓ Ensure that the vehicle which has been jacked up is adequately supported with axle stands.
 - ✓ Wear approved eye protection. A full range of personal safety equipment is available from your Sealey dealer.
 - ✓ Wear suitable clothing to avoid snagging. Do not wear jewellery and tie back long hair.
 - ✓ Account for all tools, locking bolts, pins and parts being used and do not leave them in or near the engine.
 - x **DO NOT** use an impact wrench with this tool.
- IMPORTANT: Refer to the vehicle manufacturer's service instructions, or a proprietary manual, to establish the current procedure and data.**

2. INTRODUCTION & APPLICATION

2.1 Introduction: Remove/Install rear sub-frame bushes in Mondeo. Can be used in situ – no need to remove sub-frame from vehicle.
Applications: Ford Mondeo 2001, 10/2000 onwards

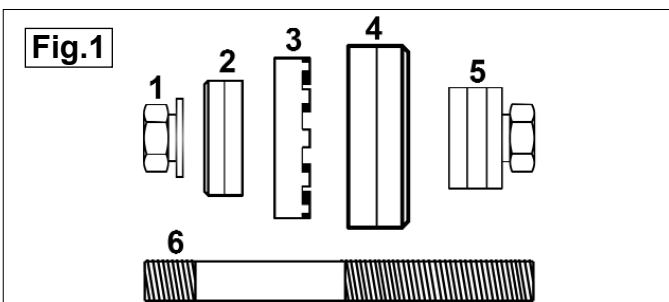

ITEM	PART NO:	DESCRIPTION
1	VSE4778.01	FLANGE NUT
2	VSE4778.02	LARGE WASHER
3	VSE4778.03	REMOVAL PLATE
4	VSE4778.04	COMPRESSOR SLEEVE
5	VSE4778.05	FORCE NUT ASSEMBLY
6	VSE4778.06	FORCE SCREW

3. OPERATION

- 3.1 Ensure that the vehicle is adequately supported on axle stands before working under the vehicle.
- 3.2 Although there is no need to remove the sub-frame from the vehicle it will be necessary to lower it to gain access to both sides of the bush housing.
- 3.3 Remove the rear wheels. To lower the sub-frame remove the four retaining bolts taking care not to damage the brake hoses. **For a detailed and up to date breakdown of this procedure refer to the vehicle manufacturer's service instructions, or a proprietary manual.**

NOTE: It is our policy to continually improve products and as such we reserve the right to alter data, specifications and component parts without prior notice. **IMPORTANT:** No liability is accepted for incorrect use of product. **WARRANTY:** Guarantee is 12 months from purchase date, proof of which will be required for any claim. **INFORMATION:** For a copy of our latest catalogue and promotions call us on 01284 757525 and leave your full name and address, including postcode.

- 3.4 To remove the old bush, assemble the tool onto the bush and sub-frame as shown in Fig.2. Ensure that the force screw **6** is well lubricated prior to assembly. Hold the flange nut **1** with a 24mm ring spanner. Using a ratchet wrench with a 24mm deep socket turn the nut on the force nut assembly **5** clockwise to drive the bush out of its housing. **Do not use an impact wrench.**

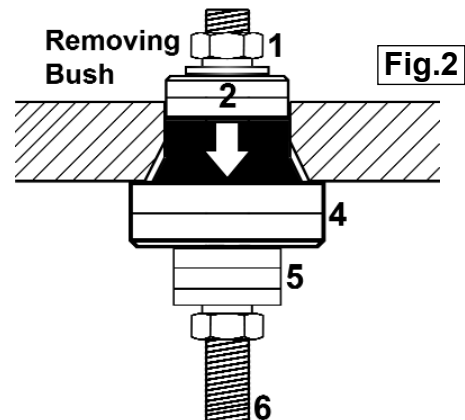

- 3.5 The new bush will be inserted using a Loctite adhesive. For this reason ensure that the bush housing and surrounding area are thoroughly cleaned and de-greased. Apply the Loctite to the bush/housing as directed by your maintenance/repair manual.
- 3.6 To insert the new bush, assemble the tool and bush onto the subframe as shown in Fig.3. Ensure that the threaded rod **6** is well lubricated prior to assembly. Hold the hex nut **1** with a 24mm ring spanner. Using a ratchet wrench with a 24mm deep socket turn the nut on the force nut assembly **5** clockwise to drive the bush into the housing.
- 3.7 Refix the sub-frame and check its alignment according to your maintenance/repair manual. The Loctite must be allowed to cure for 24 hours before the vehicle can be driven.

