

DRAPER®

INSTRUCTIONS FOR 10 tonne Hydraulic Bench Press

10, 20 & 30 tonne Hydraulic Floor Presses

Stock Nos. 10582 10583
10598 10599

Part Nos. HBP/10B HFP/10B
HFP/20B HFP/30B

IMPORTANT: PLEASE READ THESE INSTRUCTIONS CAREFULLY TO ENSURE THE SAFE AND EFFECTIVE USE OF THIS PRODUCT.

CE



10582
10 tonne hydraulic
bench press



10583
10 tonne hydraulic
floor press



10598
20 tonne hydraulic
floor press

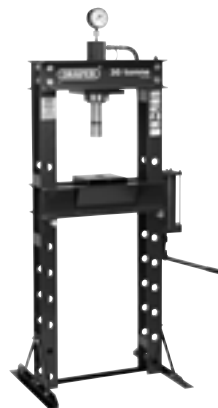

10599
30 tonne hydraulic
floor press

DRAPER®

GENERAL INFORMATION

These instructions accompanying the product are the original instructions. This document is part of the product, keep it for the life of the product passing it on to any subsequent holder of the product. Read all these instructions before assembling, operating or maintaining this product.

This manual has been compiled by Draper Tools describing the purpose for which the product has been designed, and contains all the necessary information to ensure its correct and safe use. By following all the general safety instructions contained in this manual, it will ensure both product and operator safety, together with longer life of the product itself.

All photographs and drawings in this manual are supplied by Draper Tools to help illustrate the operation of the product.

Whilst every effort has been made to ensure the accuracy of information contained in this manual, the Draper Tools policy of continuous improvement determines the right to make modifications without prior warning.

1. TITLE PAGE

1.1 INTRODUCTION:

USER MANUAL FOR:

10 tonne HYDRAULIC BENCH PRESS

Stock no. 10582

Part no. HBP/10B

10, 20 & 30 tonne HYDRAULIC FLOOR PRESS

Stock nos. 10583, 10598, 10599

Part nos. HFP/10B, HFP/20B, HFP/30B

1.2 REVISIONS:

Date first published November 2011

As our user manuals are continually updated, users should make sure that they use the very latest version.

Downloads are available from: <http://www.drapertools.com/b2c/b2cmanuals.pgm>

DRAPER TOOLS LIMITED

HURSLEY ROAD

CHANDLER'S FORD

EASTLEIGH

HAMPSHIRE

SO53 1YF

UK

WEBSITE: www.draper.co.uk

PRODUCT HELPLINE: +44 (0) 23 8049 4344

GENERAL FAX: +44 (0) 23 8026 0784

1.3 UNDERSTANDING THIS MANUALS SAFETY CONTENT:

WARNING! Information that draws attention to the risk of injury or death.

CAUTION! Information that draws attention to the risk of damage to the product or surroundings.

1.4 COPYRIGHT © NOTICE:

Copyright © Draper Tools Limited.

Permission is granted to reproduce this publication for personal & educational use only.

Commercial copying, redistribution, hiring or lending is prohibited.

No part of this publication may be stored in a retrieval system or transmitted in any other form or means without written permission from Draper Tools Limited.

In all cases this copyright notice must remain intact.

2. CONTENTS

2.1 CONTENTS

<i>Page content</i>	<i>Page</i>
1 TITLE PAGE	
1.1 INTRODUCTION	2
1.2 REVISION HISTORY	2
1.3 UNDERSTANDING THIS MANUAL	2
1.4 COPYRIGHT NOTICE	2
2 CONTENTS	
2.1 CONTENTS	3
3 GUARANTEE	
3.1 GUARANTEE	4
4 INTRODUCTION	
4.1 SPECIFICATION	5
4.2 HANDLING & STORAGE	6
5 HEALTH & SAFETY INFORMATION	
5.1 GENERAL SAFETY INSTRUCTIONS FOR HYDRAULIC PRESS USE	7
5.2 ADDITIONAL SAFETY INSTRUCTIONS FOR HYDRAULIC PRESS USE	9A
6 TECHNICAL DESCRIPTION	
6.1 IDENTIFICATION	10B
6.2 MAIN COMPONENT DESCRIPTIONS	10A
7 UNPACKING & CHECKING	
7.1 PACKAGING	11
7.2 WHAT'S IN THE BOX?	11
8 ASSEMBLY	
8.1 SUPPORT FEET AND UPRIGHT SUPPORT ASSEMBLY	14
8.2 FITTING THE RAM SLIDE	15
8.3 FITTING THE HYDRAULIC PUMP UNIT	15
8.4 FITTING THE RAM UNIT	16
8.5 PRESSURE GAUGE AND HOSE ASSEMBLY	17
8.6 TIGHTEN ALL FIXINGS	17
8.7 SETTING THE TABLE	17
9 OPERATING INSTRUCTIONS	
9.1 PUMP UNIT	18
9.2 POSITIONING	18
10 MAINTENANCE AND TROUBLESHOOTING	
10.1 CARE AND MAINTENANCE	19
10.2 TROUBLESHOOTING	19
11 EXPLANATION OF SYMBOLS	
11.1 EXPLANATION OF SYMBOLS	20
12 DISPOSAL	
12.1 DISPOSAL	21
DECLARATION OF CONFORMITY	ENCLOSED

3. GUARANTEE

3.1 GUARANTEE

Draper tools have been carefully tested and inspected before shipment and are guaranteed to be free from defective materials and workmanship.

Should the press develop a fault, please return the complete press to your nearest distributor or contact Draper Tools Limited, Chandler's Ford, Eastleigh, Hampshire, SO53 1YF. England.

Telephone Sales Desk: (023) 8049 4333 or Product Helpline (023) 8049 4344.

A proof of purchase must be provided with the press.

If upon inspection it is found that the fault occurring is due to defective materials or workmanship, repairs will be carried out free of charge. This guarantee period covering parts/labour is 12 months from the date of purchase except where tools are hired out when the guarantee period is ninety days from the date of purchase. This guarantee does not apply to normal wear and tear, nor does it cover any damage caused by misuse, careless or unsafe handling, alterations, accidents, or repairs attempted or made by any personnel other than the authorised Draper warranty repair agent.

Note: If the press is found not to be within the terms of warranty, repairs and carriage charges will be quoted and made accordingly.

This guarantee applies in lieu of any other guarantee expressed or implied and variations of its terms are not authorised.

Your Draper guarantee is not effective unless you can produce upon request a dated receipt or invoice to verify your proof of purchase within the guarantee period.

Please note that this guarantee is an additional benefit and does not affect your statutory rights.

Draper Tools Limited.

4. INTRODUCTION

4.1 SPECIFICATION

10 tonne Hydraulic Bench Press

Stock no	10582
Part no	HBP/10B
Capacity	10 tonne
Ramstroke	190mm
Max. height (ram to table) approx	310mm
Min. height (ram to table) approx	140mm
Table aperture	110mm
Working table width	380mm
Overall height	1020mm
Weight	44kg

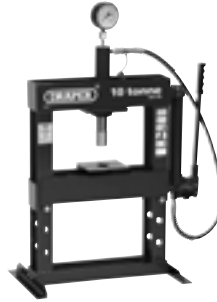

10, 20, 30 tonne Hydraulic Floor Press

Stock no	10583	10598	10599
Part no.	HFP/10B	HFP/20B	HFP/30B
Capacity	10 tonne	20 tonne	30 tonne
Ramstroke	190mm	220mm	240mm
Max. height (ram to table) approx.	985mm	930mm	1155mm
Min. height (ram to table) approx.	80mm	75mm	75mm
Table aperture approx.	87mm	105mm	125mm
Working table width approx.	395mm	455mm	460mm
Overall height approx.	1660mm	1690mm	1825mm
Weight approx.	59kg	83kg	124kg



4. INTRODUCTION

4.2 HANDLING & STORAGE

Warning. To ensure safety, the press and individual components are necessarily manufactured from heavy components. Assembly is to be completed by at least two persons. Assembly cannot be safely achieved by only one person.

Once these presses are assembled, they are heavy. Never attempt to move on your own, and ensure you comply with all requirements of Health and Safety at work regulations 1999 and Manual Handling operations regulations 1992.

5. HEALTH & SAFETY INFORMATION

5.1 GENERAL SAFETY INSTRUCTIONS FOR HYDRAULIC PRESS USE

Warning. Please read the following instructions carefully, failure to do so could lead to serious injury.

Important. Draper Tools Limited recommends that this hydraulic press should not be modified or used for any application other than that for which it was designed. If you are unsure of its relative applications do not hesitate to contact us in writing and we will advise you.

1. Know your hydraulic press.

Read and understand the owner's manual and labels affixed to the tool. Learn its application and limitations as well as the specific potential hazards peculiar to this tool.

2. Keep work area clean.

Cluttered areas and benches invite accidents. Ensure that work area is clear of any hazards at all time. Keep a safe working area, ensuring children and all visitors should be kept a safe distance from work area.

3. Wear proper clothing.

Do not wear loose clothing, neckties or jewellery (rings, wristwatches) to catch in parts. NONSLIP footwear is recommended. Roll long sleeves above the elbow.

4. Use safety goggles (head protection).

Wear CE approved safety goggles at all times. Normal spectacles only have impact resistant lenses, they are NOT safety glasses. Also use face or dust mask if application is dusty.

5. Stay alert.

Always watch what you are doing and use common sense. Do not operate a press when you are tired or under the influence of alcohol or drugs.

6. Never stand on tool.

Do not store materials above or near the press, so that it is necessary to stand on the press to reach them.

7. Check damaged parts.

Check for damage to parts, breakage of parts, mountings and any other conditions that may affect its operation. A part that is damaged should be properly repaired or replaced.

8. Maintain tools with care.

Keep tools clean for the best and safest performance. Follow instructions for lubricating and changing accessories. Always keep the hand grips on the tool clean, dry and free of oil and grease.

9. Use recommended accessories.

Consult the owners manual for recommended accessories. Follow the instructions that accompany the accessories. The use of improper accessories may cause hazards.

5. HEALTH & SAFETY INFORMATION

10. Secure work.

Consult the owners manual for recommended accessories. Follow the instructions that accompany the accessories. The use of improper accessories may cause hazards.

11. Do not overreach.

Keep proper footing and balance at all times.

12. Use right tool.

Do not force the press or attachment to do a job for which it was not designed.

13. Do not force tool.

It will do the job better and safer at the rate for which it was designed.

5. HEALTH & SAFETY INFORMATION

5.2 ADDITIONAL SAFETY INSTRUCTIONS FOR HYDRAULIC PRESS USE

1. Never exceed the maximum load capacity of the ram.
2. Do not over extend the ram, as it is possible to force the plunger out of the top of the ram or create a hydraulic lock in the ram unit.
3. When coupler valves are disconnected always insert dust cap to keep the oil lines clean.
4. Do not use unless the ram head is pressing centrally on the workpiece. Incorrectly inserted workpieces can be ejected at high force and speed causing considerable risk to both press and user. Always ensure the workpiece is safely and securely positioned before and during pressing. If the load is not centred to the ram plunger, pump carefully. If you have to use excessive pressure to pump the ram, stop the operation and adjust the set-up so that the load is more central. This should decrease the effort required.
5. Do not drop any heavy objects onto the hose, and do not allow the hose to kink.
6. Always allow clearance for the hose to avoid damage to the hose and couplers.
7. Keep the equipment away from the heat or fire, as this may damage or weaken the equipment.

Blank page

6. TECHNICAL DESCRIPTION

6.1 IDENTIFICATION

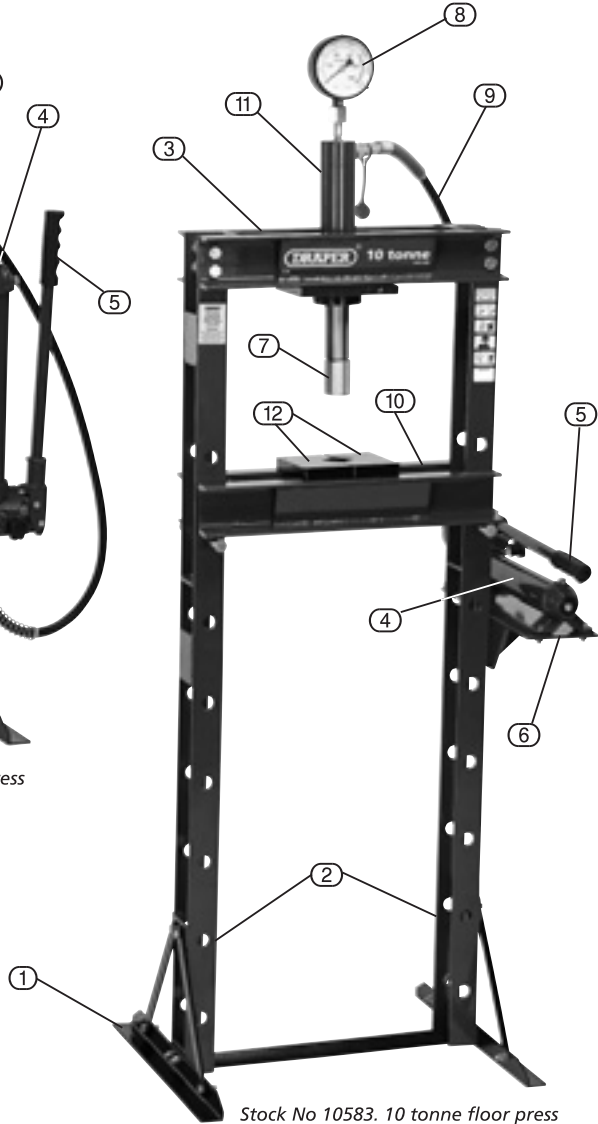
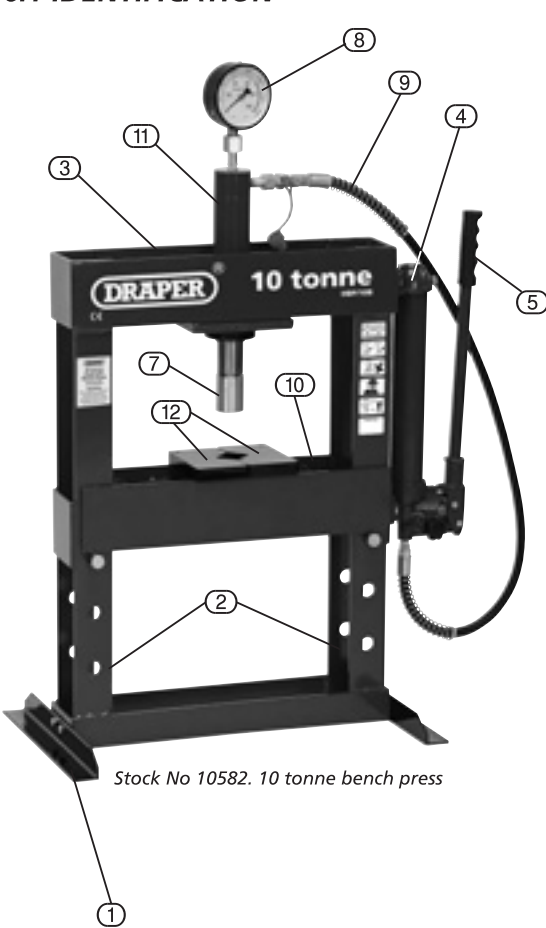

① Support feet

② Press uprights

③ Ram slide

④ Hydraulic pump unit

⑤ Pump lever

⑥ Pump plate

⑦ Ram pressure cap

⑧ Pressure gauge

⑨ Hose

⑩ Table aperture

⑪ Ram unit

⑫ Table plates

6. TECHNICAL DESCRIPTION

6.2 MAIN COMPONENT DESCRIPTIONS

The **TABLE** is the area in which the workpiece is secured before pressing can commence.

The **RAM** is the extending, hydraulically operated tube that applies the force to the workpiece.

The **PUMP** is the item that applies the hydraulic pressure, via differential pistons, to the ram.

7. UNPACKING & CHECKING

7.1 PACKAGING

Carefully remove the contents from the packaging and examine them for any sign of damage that may have happened during shipping. Do not use damaged items, have them replaced before assembling the press.

The packaging material should be retained at least during the guarantee period: in case the press needs to be returned for repair.

Warning! Some of the packaging materials used may be harmful to children. Do not leave any of these materials in the reach of children.

If any of the packaging is to be discarded, make sure they are disposed of correctly; according to local regulations.

7.2 WHAT'S IN THE BOX?

Lay the contents out and check them against one of the following diagrams appropriate to your specific machine. If any part is damaged or missing; please contact the Draper Helpline (the telephone number appears on the Title page) and do not attempt to assemble or use the product.

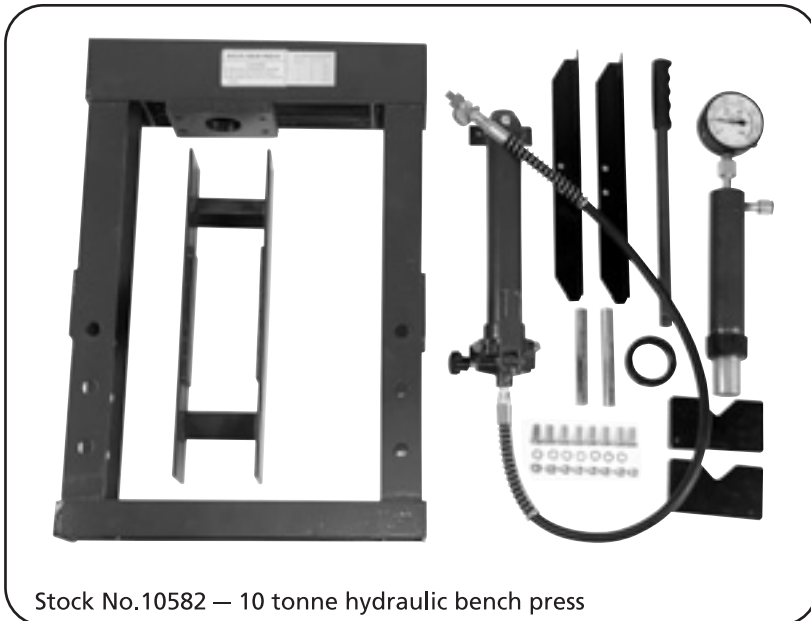

7. UNPACKING & CHECKING

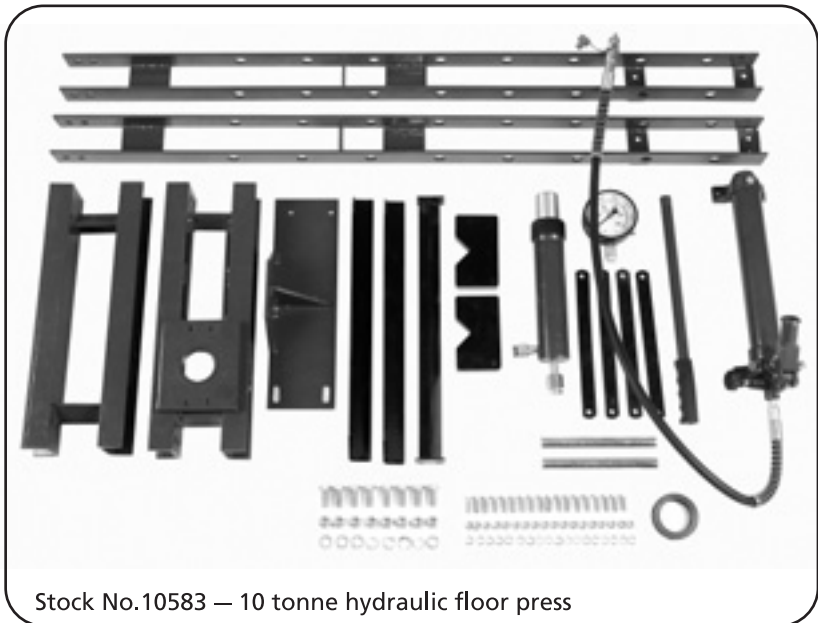

Stock No.10583 — 10 tonne hydraulic floor press

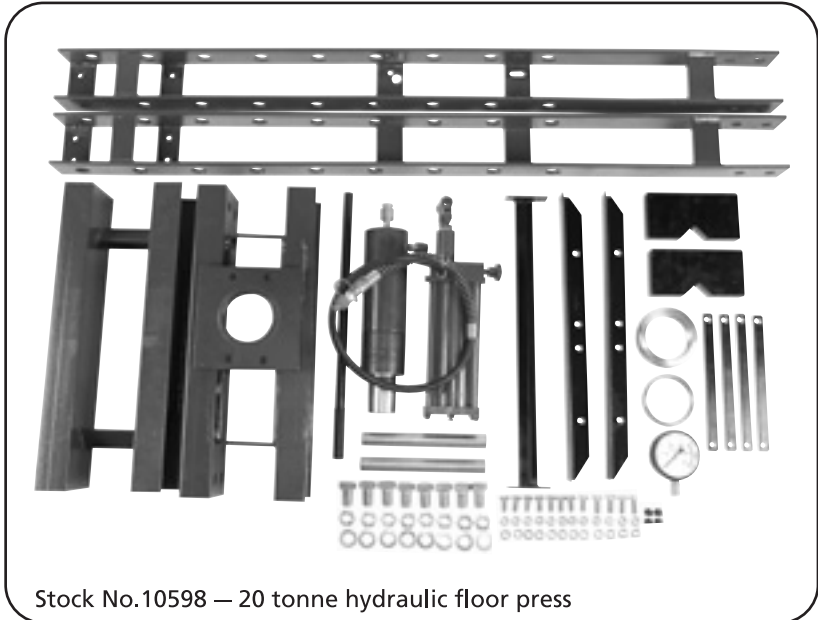

Stock No.10598 — 20 tonne hydraulic floor press

7. UNPACKING & CHECKING

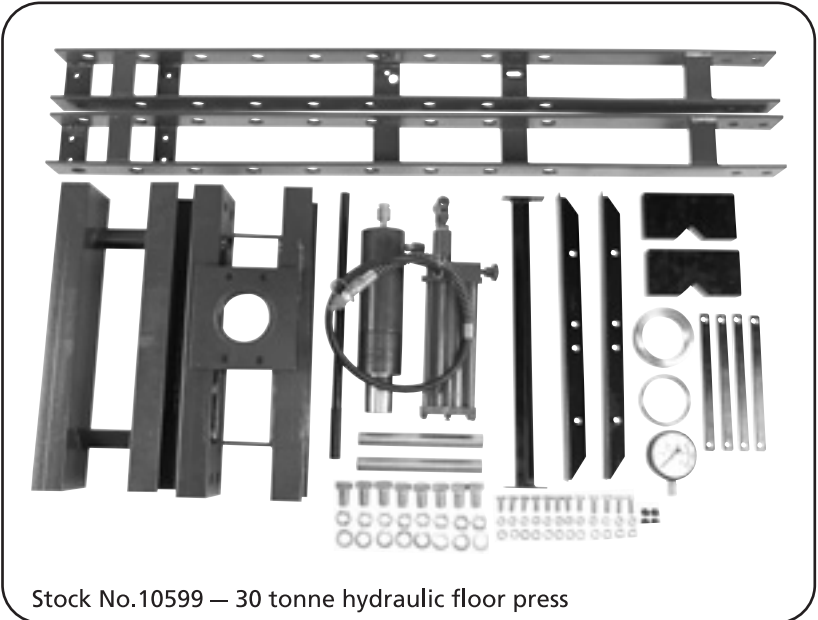

Stock No.10599 — 30 tonne hydraulic floor press

8. ASSEMBLY

WARNING: DUE TO THE SIZE AND WEIGHT OF THE COMPONENTS OF THE PRESSES, ASSEMBLY MUST BE CARRIED OUT WITH AT LEAST TWO PERSONS. ASSEMBLY MUST NOT BE ATTEMPTED BY A SINGLE PERSON.

8.1 SUPPORT FEET AND UPRIGHT SUPPORT ASSEMBLY – FIGS. 1 - 3

Bolt cross feet (A) and supports (B) to bottom of main press uprights (C) (Note: supports (B) are not required for Stock No.10582 10 tonne bench press).

Note: **Do Not** fully tighten the bolts until assembly is complete.



FIG. 1 – 10 tonne bench press

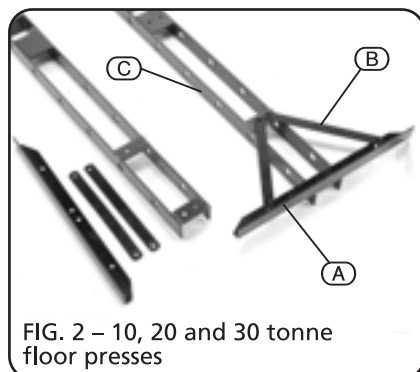

FIG. 2 – 10, 20 and 30 tonne floor presses

On the 10, 20 and 30 tonne floor presses, use the four longer bolts (D) to secure cross bar through uprights and feet (E).

Note: **Do Not** fully tighten the bolts until assembly is complete.

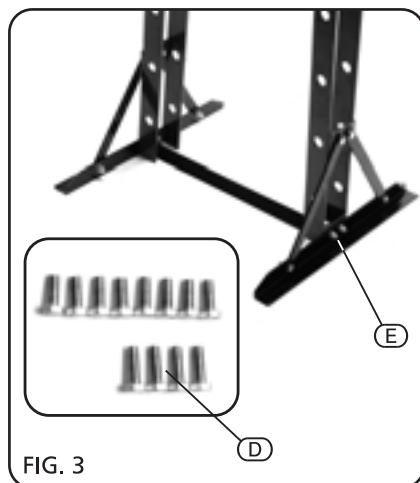

FIG. 3

8. ASSEMBLY

8.2 FITTING THE RAM SLIDE – FIG. 4

Fit the ram slide (F), ensuring that it is square before securing the 8 nuts, bolts and washers. (Note: the ram slide is already fitted to the 10 tonne bench press).

Note: the uprights operate in tension, so to assemble, the base bolts must not be fully tightened or alignment of the fixing holes is not possible.

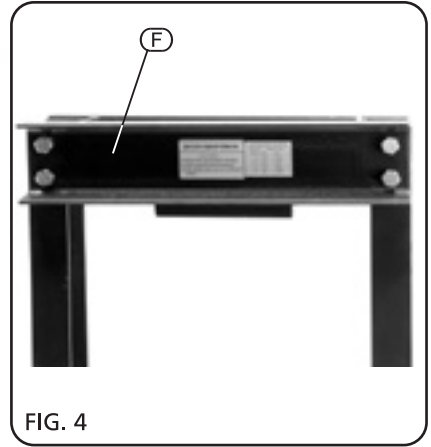

8.3 FITTING THE HYDRAULIC PUMP UNIT – FIG. 5

Fit the hydraulic pump unit (G) using the plate (H) if required. (Note: the position of the hydraulic pump can differ from each unit). The handle mechanism must be operable from the front of the press.

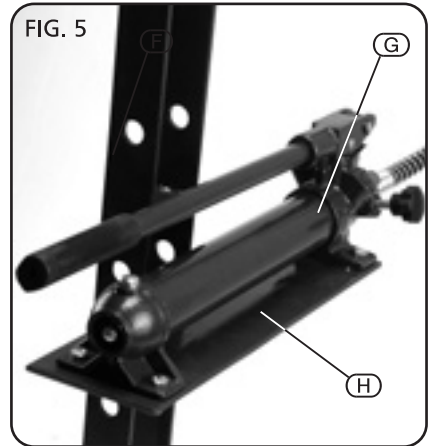

8. ASSEMBLY

8.4 FITTING THE RAM UNIT – FIGS. 6 - 8

Remove thread cover ① and ram cover ②.

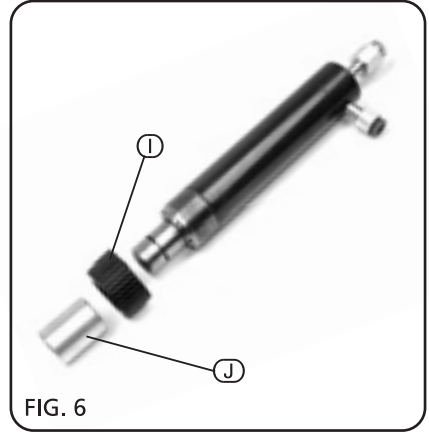

Fit ram unit with locking ring ③.

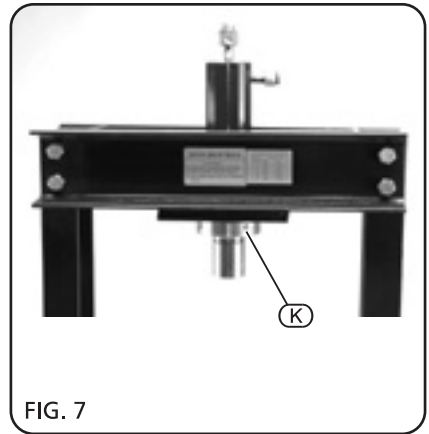

Note: on the 20 and 30 tonne floor presses, the ram slider must be dismantled on one side to fit ram – (Fig. 8).

Caution: The ram plate is held in tension with springs. Ensure the retaining bolts are removed carefully or the springs will eject the clamp plate with force.



8. ASSEMBLY

8.5 PRESSURE GAUGE AND HOSE ASSEMBLY – FIGS. 9 - 10

Remove the thread cap on the ram head, and ensuring the o-ring (L) is fitted correctly, fit the gauge ensuring the gauge is easily readable from the front of the press (M), screw in the hose (N).

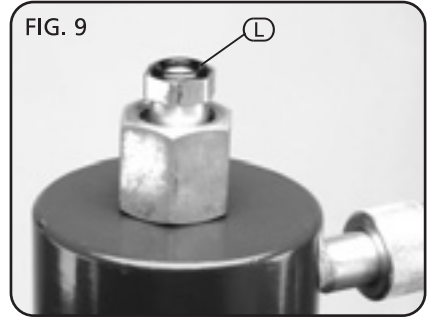

8.6 TIGHTEN UP ALL FIXINGS

Ensure all fixings are now fully tightened and that the press frame is square.

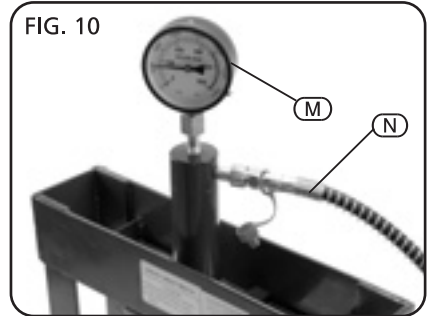

8.7 SETTING THE TABLE – FIGS. 11 - 12

Using the locating pins (O) set the table at the required height (Note: to insert table it must be angled between the frame uprights). Ensure locating pins are an equal distance from either side (Fig. 12).

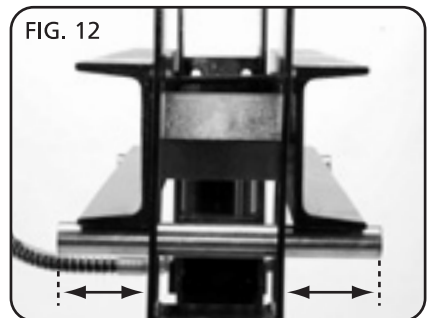
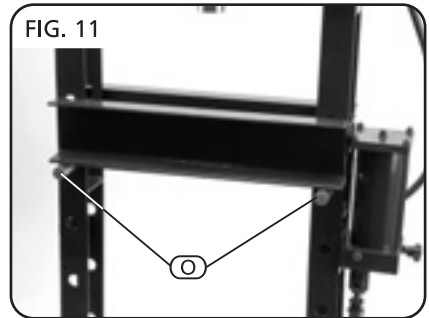

9. OPERATING INSTRUCTIONS

9.1 PUMP UNIT – FIG. 13

Note: Before use, the pump/ram must be bled to ensure air is ejected and oil is fully circulated. To bleed, open release valve (P) by turning anti-clockwise (no more than 2 complete turns) and fully pump handle a minimum of 10 times. Then close valve and unit will be ready for use.

- i. Ensure you have securely fastened the couplings before pumping.
- ii. Firmly close the release valve (P) by turning it in a clockwise direction.
- iii. Apply pressure to the pump (Q) by pumping the handle (R) up and down.
- iv. To release the pressure turn the valve anti-clockwise (no more than 2 complete turns).

9.2 POSITIONING – FIGS. 14 - 16

Ram: To move the ram (S) into the required position, loosen the bolts and slide into place. Tighten the bolts before operating the ram.

Work table: The height of the work table (T) is adjusted by removing the support pins (U) and relocating in a higher or lower hole in the main frame (V).

Note: The table is heavy and it should always remain level.

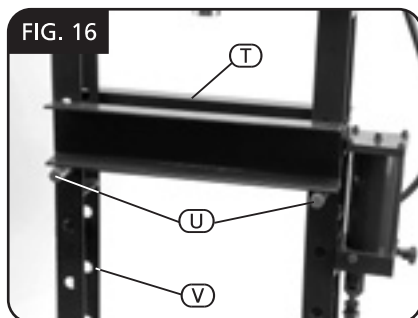
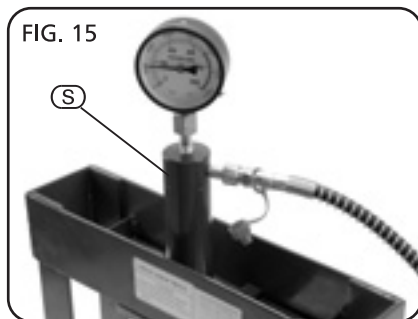
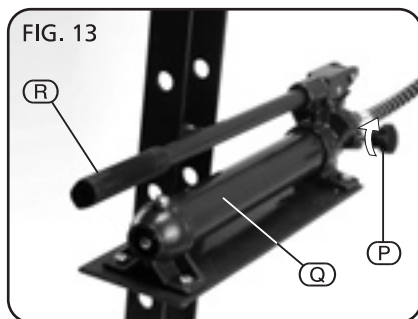

10. MAINTENANCE AND TROUBLESHOOTING

10.1 CARE AND MAINTENANCE

- i. When your press is not in use, the pump unit should be stored with the release valve open and the ram fully retracted.
- ii. To check oil level, place the pump unit in an upright position. As indicated in the diagram opposite. Remove the dip stick and the oil level will be indicated. If required add hydraulic oil until it is level with the full mark on the stem. **YOUR PRESS WAS FILLED AT THE FACTORY WITH HIGH GRADE HYDRAULIC OIL. ONLY USE APPROVED OIL*.**
- iii. After extensive use, the oil supply should be replaced to ensure longer equipment life. To drain, remove the dip stick and open release valve. Ensure that no dirt gets into the system. Refill with approved hydraulic oil, as paragraph 2.

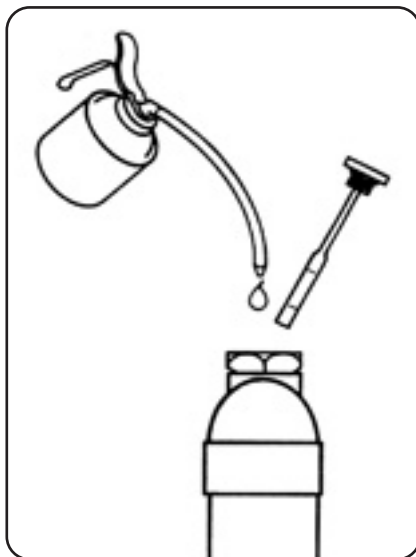

*We recommend *Shell Telus 22*.

10.2 TROUBLESHOOTING

TROUBLE	PROBABLE CAUSE	REMEDY
Pump unit will not work.	Dirt on valve seats/ worn seals.	Bleed pump unit or replace with new seals.
Pump unit will not produce pressure OR Pump unit feels unsteady under load. OR Pump unit will not lower completely.	Air block Air block Air block	(1) Open the release valve and remove oil filler plug. (2) Pump handle a couple of full strokes and close the release valve. (3) Replace filler plug.
Pump unit will not produce pressure.	The reservoir could be overfilled or low on hydraulic oil level	To check the oil level – remove the filler plug. Top up oil to correct level.
Pump unit feels unsteady under load.	The pump cup seal could be worn out	Replace the cup seal with a new one.
Pump unit will not lower completely	Air block	Release air by removing filler plug.

11. EXPLANATION OF SYMBOLS

11.1 EXPLANATION OF SYMBOLS



Warning! Ejection hazards.
Wear safety goggles



Warning!
Read the instruction manual



Warning! Contact hazards.
Keep hands away from moving
parts



Warning! Disable the machine
before attempting to maintain it

12. DISPOSAL

12.1 DISPOSAL

- At the end of the machine's working life, or when it can no longer be repaired, ensure that it is disposed of according to national regulations.
- Contact your local authority for details of collection schemes in your area.

In all circumstances:

- Do not incinerate.
- Do not abandon in the environment.

- **DRAPER TOOLS LIMITED,**
Hursley Road, Chandler's Ford,
Eastleigh, Hampshire. SO53 1YF. U.K.
- **Helpline:** (023) 8049 4344
- **Sales Desk:** (023) 8049 4333
- **Internet:** www.draper.co.uk
- **E-mail:** sales@drapertools.com
- **Sales Fax:** (023) 8049 4209
- **General Enquiries:** (023) 8026 6355

- **Service/Warranty Repair Agent**
For aftersales servicing or warranty repairs, please
contact the Draper Tools Helpline for details of an
agent in your local area.

YOUR DRAPER STOCKIST